

Smart LifestyleTM

A U S T R A L I A

Installation & Operation Manual

Air-source Heat Pump Water Heater

Please read the manual carefully before using the product,
and properly keep this manual for reference.
Please entrust professionals to install this product.

Introduction

Dear Users:

This manual is for the reference of the installation, operation and maintenance of this water heater and to provide important safety information. Please read all the contents of this manual before installing and using this water heater. Please keep this book properly for future reference.

Table of Contents

Safety Precautions	1
Parts and Functions	4
Installation Instructions	5
Pipeline Connection	7
Electrical Connection	9
Usage Methods	10
Operating Instructions	11
Trial Operation	15
Maintenance and Troubleshooting	15

Safety Precautions

- Please make sure that you have read the chapter "Safety Precautions" of this manual before using this product. "Safety Precautions" provides very important safety issues, please follow the rules.

Warning

1. Household electricity must have reliable grounding;
2. Leakage protection devices must be installed for household electricity;
3. Do not remove any permanent instructions, labels or parameter plates on the casing of the product or inside any plates;
4. The product should be installed on a safety tray when installed indoor.

Warning

1. Please entrust dealers or professionals to install the product. The installation personnel must have relevant professional knowledge. Improper installation may cause fire, electric shock, personal injury, water leakage, etc.
2. Please purchase any articles designated by our company, if necessary.
3. Please abide by the regulations of the local electric company when connecting the power supply.
4. When the hot water machine needs to be moved or reinstalled, please entrust dealers or professionals to operate.
5. Never modify or repair it by yourself. Improper repair may cause fire, electric shock, personal injury, water leakage and other accidents. Be sure to entrust dealers or professionals to repair it.

Attentions

1. The socket must be reliably grounded. The socket and power plug shall be kept dry to prevent electricity leakage. Always check whether the plug and socket fit well. The inspection method is as follows: insert the power plug into the socket, start the machine for about half an hour, turn off and unplug, and check whether the pins of the plug are hot. If hot (about over 50°C), please replace the socket with a qualified one with good contact, so as to avoid plug overheating and being burnt, or even causing fire and other personal injury accidents due to poor contact.
2. In places or walls where water may splash on, the power socket shall not be installed less than 1.8 meters, and ensure that water will not splash on the socket, and it shall not be installed in places out of reach of children.
3. At any cold water inlet, temperature and pressure safety valves must be installed. If the lowest water point is more than 3m below the hot water outlet of the water tank, a vacuum breaking valve must be installed at the highest point of the water outlet of the water tank.
4. During the heating process, water drops may drip from the pressure relief hole of the temperature and pressure safety valve, which is a normal phenomenon. If there is a large amount of water leakage, please ask for professionals to repair it in time. Never block the pressure relief hole, otherwise it may cause damage to the water heater and lead to safety accidents. The drain pipe connected to the pressure relief hole shall be kept inclined downward and installed in a frost-free environment.
5. As the water temperature inside the water tank of the water heater is very high (hot water exceeding 50°C will burn the human body. When using water initially, do not spray the water directly to the human body. Adjust the water temperature first to avoid scalding;
6. If the power cord is damaged, replace it with the professional power cord provided by the manufacturer. The replacement shall be done by the manufacturer, the service agencies of the manufacturer, or qualified professional maintenance personnel.
7. If the parts of this unit are damaged, please send them to the professionals for maintenance and use the special maintenance parts provided by our company.
8. If the water heater is not used for a long time (more than 2 weeks), Hydrogen, which is extremely flammable, may be generated in the hot water piping system. In this case, in order to reduce the danger, it is recommended to turn on the hot water faucet for a few minutes before using any electrical appliances connected to the hot water system. If hydrogen is existed inside the system, you may hear an abnormal sound like air passing through the pipe, when the water is flowing inside the pipe. Do not smoke or light an open flame near the faucet during usage.

9. This appliance is not intended for use by persons (including children) with reduced physical, sensory or mental capabilities, or lack of experience and knowledge, unless they have been given supervision or instruction concerning use of the appliance by a person responsible for their safety.
10. Children should be supervised to ensure that they do not play with the appliance.
11. This appliance incorporates an earth connection for functional purposes.
12. For appliances with type Y attachment, the instructions shall contain the substance of the following: If the supply cord is damaged, it must be replaced by the manufacturer, its service agent or similarly qualified persons in order to avoid a hazard.
13. CAUTION: In order to avoid a hazard due to inadvertent resetting of the thermal cut-out, this appliance must not be supplied through an external switching device, such as a timer, or connected to a circuit that is regularly switched on and off by the utility.
14. Maximum inlet water pressure is 0.65 MPa, minimum inlet water pressure is 0.15 MPa.
15. Appliances accessible to the general public.
16. DANGER: The operation of the thermal cut-out indicates a possibly dangerous situation. Do not reset the thermal cut-out until the water heater has been serviced by a qualified person.
17. DANGER: Failure to operate the relief valve easing gear at least once every six months may result in the water heater exploding. Continuous leakage of water from the valve may indicate a problem with the water heater.
18. The water may drip from the discharge pipe of the pressure-relief device and that this pipe must be left open to the atmosphere; the pressure-relief device is to be operated regularly to remove lime deposits and to verify that it is not blocked; how the water heater can be drained.
19. The instructions shall state that the fixed wiring insulation must be protected, for example, by insulating sleeving having an appropriate temperature rating.
20. If the water supply pressure exceeds the rated pressure, a pressure reducing valve is to be fitted in the installation.
21. The type or characteristics of the pressure-relief device and how to connect it, unless it is incorporated in the appliance; a discharge pipe connected to the pressure-relief device is to be installed in a continuously downward direction and in a frost-free environment; the instructions for closed water heaters incorporating a heat exchanger shall give details on the installation of control devices and the temperature settings that are necessary to prevent operation of the thermal cut-out caused by the heat from the exchanger.
22. Water heater is permanently connected to water mains.
23. A typical value of acceptable water hardness or total dissolved solids is 600 mg/Liter.

Warning

1. Warning for continued safety of this appliance it must be installed, operated and maintained in accordance with the manufacturer's instructions.
2. Warning this appliance may deliver water at high temperature. Refer to the plumbing code of Australia (PCA), local requirements and installation instructions to determine if additional delivery. Temperature control is required.
3. If hot water system isn't used for 2 weeks or more, a quantity of HIGHLY flammable hydrogen gas may accumulate in the water heater. To dissipate this gas safely, it is recommended that a hot tap be turned on for several minutes or until discharge of gas ceases. Use a sink, basin, or bath outlet, but not a dishwasher, clothes washer or other appliance. During this procedure, there must be no smoking, open flame or any electrical appliance operating nearby. If hydrogen is discharged.

Attentions

1. Hose-set should not be used.
2. Appliance shall be installed in accordance with national wiring regulations.
3. Instruction concerning disconnection incorporated in the fixed wiring is in accordance with AS/NZS 3000.
4. Installed in compliance with Australian plumbing standard AS3500.4.
5. It is recommended that the temperature of this product's thermostat be set to 60°.

6. The external power box of the machine must be equipped with an air switch with leakage protection according to the requirements of the following figure; The machine can be used only after the grounding is confirmed to be reliable.

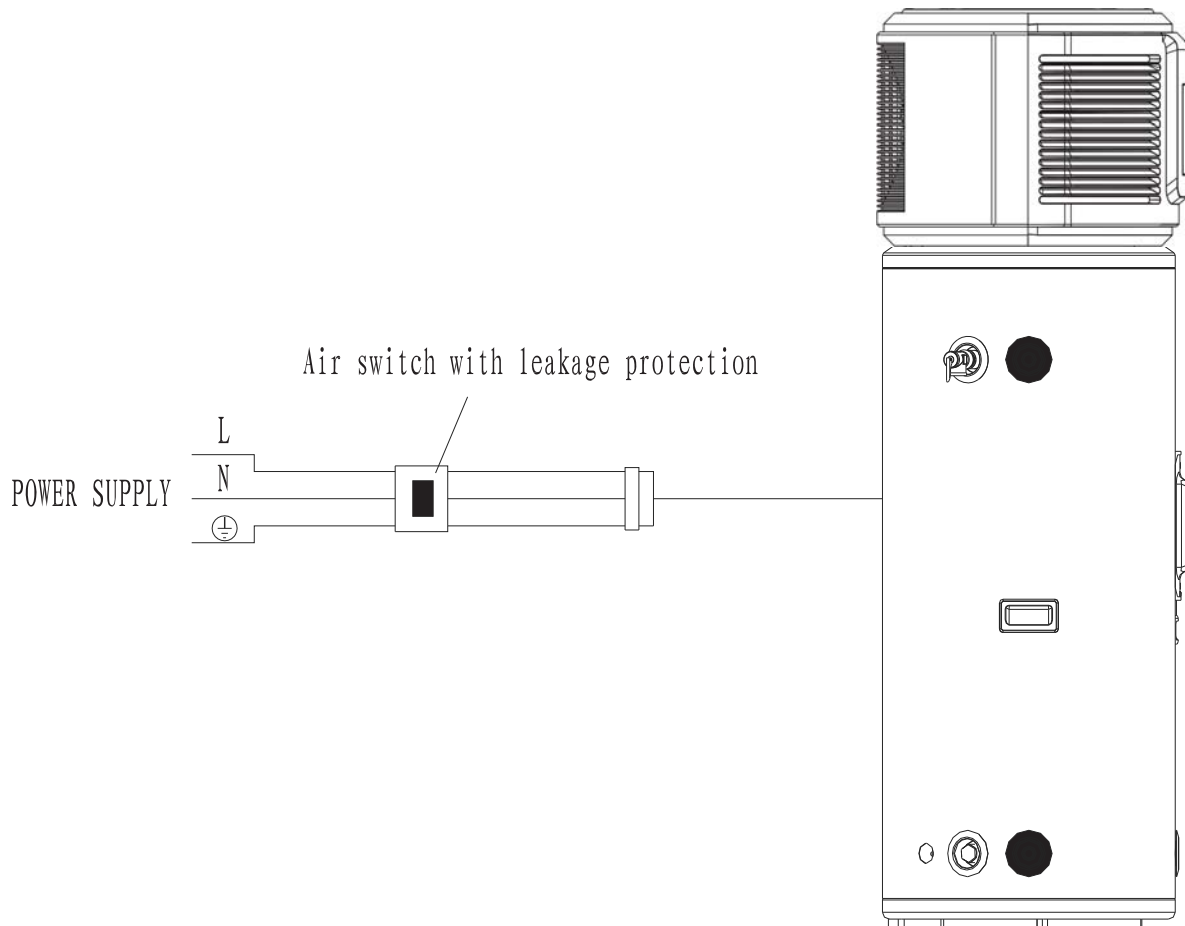

7. If the water temper is higher than 85°C , the TCO will automatically shut off the power of E-heater, it must be reset by an authorised service technician.
8. Water operating temperatures between 30°C and 70°C .
9. Water operating pressures between 0.15MPa and 0.85MPa.
10. Refrigerant filling: ① Refrigerant filling needs professional operation; ② It is recommended to fill according to the type and weight of refrigerant marked on the nameplate of the unit; ③ Fill at the check valve of the suction pipe of the unit.
11. The power cord with plug must be installed indoors.

Parts and Functions

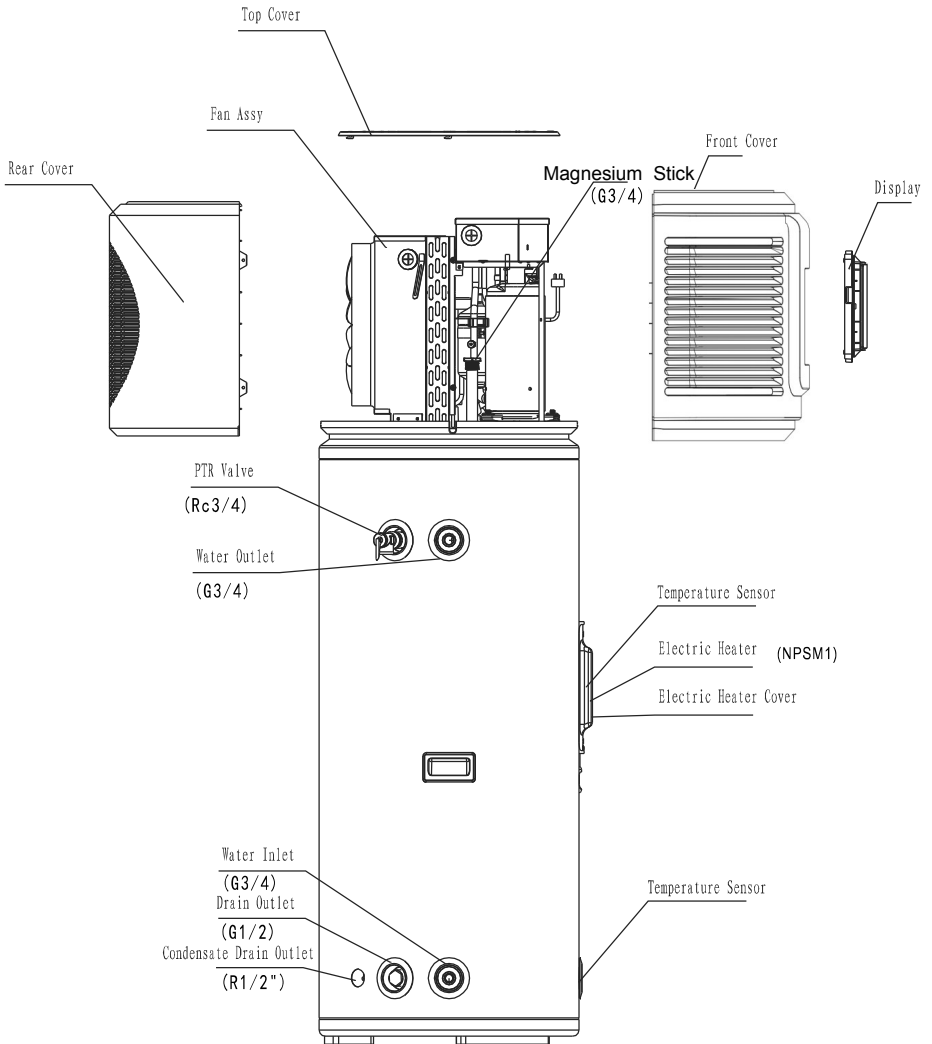

★ This diagram is only for reference, and the appearance of the product may not be the same as that of the real object. Subject to the actual model.

Installation Instructions

● Selection of installation site

1. It is not recommended to install this water heater indoors. If it is installed indoors, problems such as overflow, noise and indoor temperature drop may occur, which will affect your normal life. Please take preventive measures in advance.
2. Adequate installation and maintenance space shall be available.
3. No barrier at the inlet and outlet and no strong wind blowing.
4. Dry and ventilated place.
5. The supporting surface shall be flat (the horizontal inclination angle shall not be greater than 2°), which can bear the weight of the water heater, and the unit can be placed vertically without increasing noise and vibration.
6. Running noise and exhaust air shall not affect neighbors.
7. No combustible gas leakage.
8. Convenient for pipe connection and electrical connection.
9. If the water heater is installed on the metal part of the building, the electrical insulation must be done well, and it must conform to the relevant technical specifications of electrical equipment.

⚠ Attention

- If the temperature is below 0°C, the unit shall be installed indoors or in other places that will not freeze, so as to prevent the water pipes from being cracked and bring inconvenience to your life.
- When the temperature is below 0°C and the unit is installed outdoors, please take corresponding heat preservation measures for the water pipes according to the local minimum temperature, and the unit must be powered on to prevent pipe freezing and cracking, which will bring inconvenience to your life.
- Do not install in high temperature or under the blazing sun for a long time, otherwise the service life of products will be shortened.

Note: Installation in the following places may lead to machine failure. If unavoidable, please ask the local authorized service shop.

1. In places where there are mineral oils such as cutting oil;
2. In places where the air contains more salt, such as the sea;
3. In hot spring areas and other places where corrosive gases such as sulfur gas exist;
4. In the factories and other places where there are serious voltage fluctuations;
5. In the cars or cabins and other places with large vibration and shaking;
6. In places where there are strong electromagnetic waves;
7. In the kitchen and other places full of oil and gas;
8. In the place where acid or alkali gas evaporates;
9. In other special environments.

● Handling

1. This unit is heavy and needs more than two personnel to handle and install:
2. Please handle the unit by maintaining its ex-factory status, and do not disassemble and assemble it by yourself;
3. In order to avoid abrasion and deformation on the surface of the unit, please put a guard plate on the surface of the unit in contact with hard objects;
4. Please be careful not to make your hands or other objects come into contact with the fan blades;
5. Do not tilt greater than 15° handling, and it is strictly prohibited to lie down.

● Installation

1. If the unit is installed in basement, indoor or other confined spaces, pay attention to the circulation of exhaust and intake of air around the indoor and outdoor unit;
2. Please ensure the sufficient space for installation and maintenance;
3. Installation to confirm with AS/NZS 3500.4.

● Space required for installation and maintenance

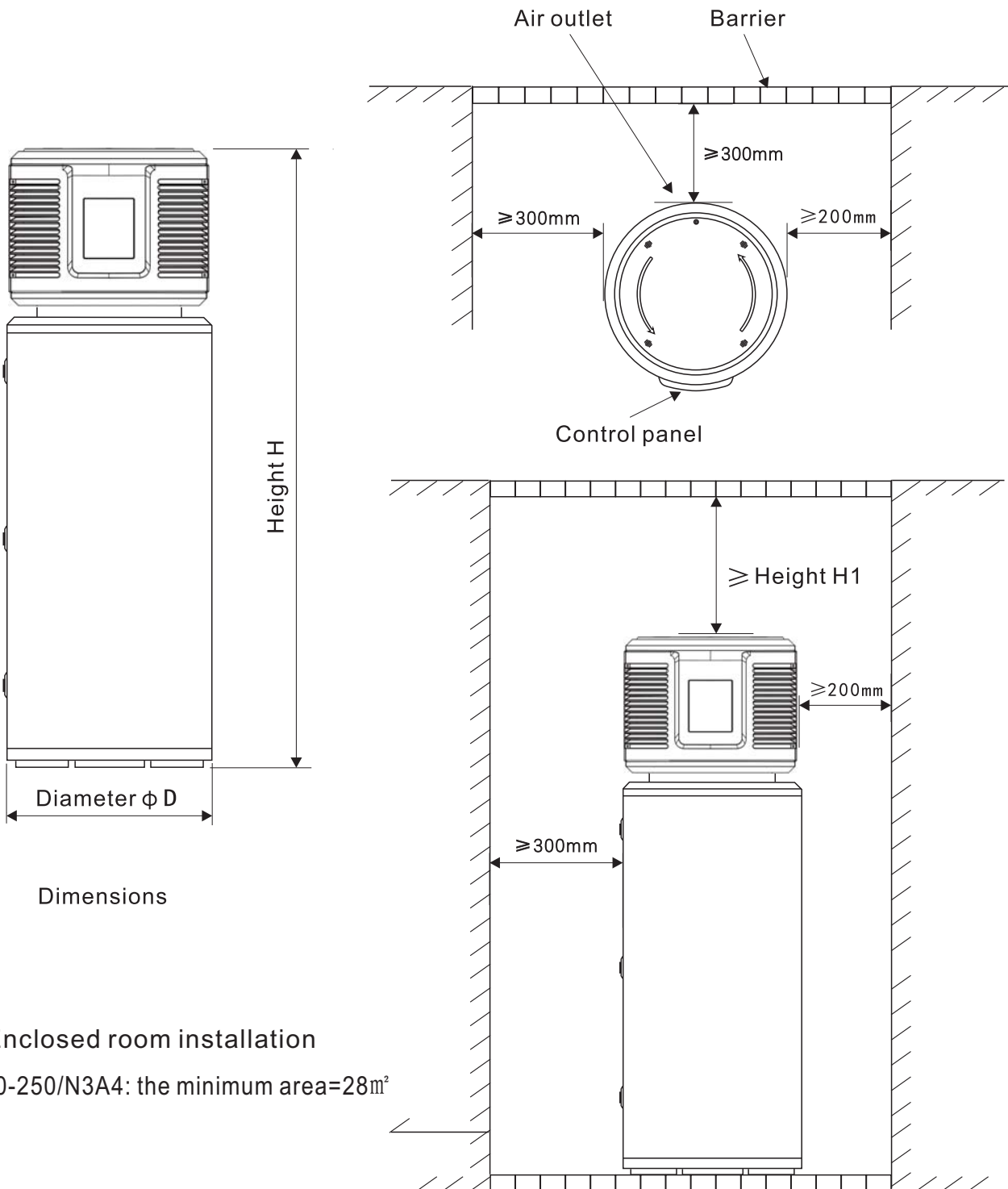

Dimension parameters

Model	SLA-R20-250/N3A4
Parameter	
Diameter ϕD (mm)	570
Height H (mm)	2140
Height H1 (mm)	1000

Pipeline Connection

● Pipeline connection diagram

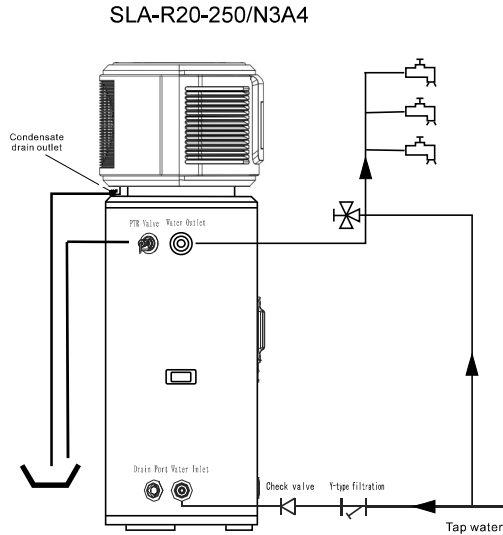

● Pipeline connection instructions

Attentions

- Do not install the water heater with iron pipes. Water systems shall only use new pipes that meet drinking water standards, such as CPVC, PPR pipes or polybutene pipes. Do not use PVC water pipes with peculiar smell;
- Water pipes and fittings shall be installed according to the above figure. If the installation and use environment is below 0°C, all water pipes must be insulated.

1. Installation of water inlet and outlet connecting pipe: The thread specification of water inlet and outlet of this machine is G3/4 "(internal thread). The service life of pipes and fittings used for installation and connection shall not be less than the service life of the water heater, and shall have sufficient high temperature resistance to prevent damage;
2. Installation of temperature and pressure safety valve: the specification of temperature and pressure installation valve is Rc3/4 "(inner tooth), 0.85 MPa. After installation according to the pipeline connection diagram, remove the bolts for fixing the safety valve handle and ensure that the outlet of the connected drain pipe is led the air;

Installation & Operation Manual

Attentions

- The temperature and pressure safety valve handle shall be pulled once every six months to remove calcium carbonate deposits. And make sure the device is not blocked. The water temperature at outlet may be very high, so pay attention to avoid scalding;
- The drain pipe shall be insulated to avoid being frozen in winter and causing safety accidents.

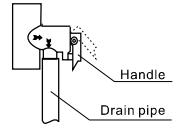

Danger

- Do not press down the safety valve handle;
- Never remove the safety valve;
- Never block the drain port;
- The drain pipe shall be led to an open drain outlet.



3. After all pipelines are installed, open the cold water inlet valve and the hot water outlet valve, and start to inject water into the water tank. When the water outlet is normally discharged, it indicates that the water in the water tank has been filled. Close the outlet valve and check whether there is water leakage at the joints of all pipelines. If there is water leakage, it shall be repaired and then injected for inspection;
4. If the inlet water pressure is less than 0.15 MPa, in order to get a larger water flow, please install a booster pump at the inlet pipe to ensure the inlet water pressure not less than 0.15 MPa. If the water supply pressure is greater than 0.65 MPa, in order to ensure the long-term safe use of your water tank, please install the pressure reducing valve at the water inlet pipe;
5. During unit working, condensed water droplets may occur at the air outlet, and the water outlet may be accidentally blocked. In such cases, water droplets will come out from the surface of the unit. To ensure that your life will not be affected or your belongings be damaged, it is recommended to use a water pan to collect the condensed water. Please refer to the following figure;
6. To smoothly drain condensate from unit, please install the main unit is on a horizontal floor. Otherwise, please ensuring the drain vent is at the lowest place. Recommended inclination angle of unit to the ground should be no more than 2°.

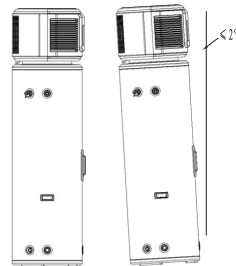
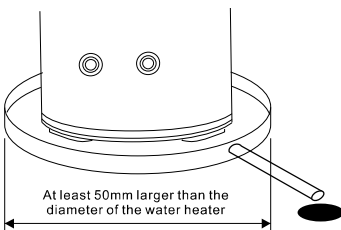

Attentions

- If the unit is installed at outdoor places where the temperature is below 0°C, please take corresponding heat preservation measures for water pipes according to the local minimum temperature to prevent freezing and cracking water pipes, which will bring convenience to your life!

Electrical Connection

● Electrical wiring

● Attentions

- The water heater shall use a special power supply, and the power supply voltage shall conform to the rated voltage;
- The power supply circuit of the water heater must be well grounded, and the grounding wire of the power supply shall be reliably connected with the external grounding wire, and the external grounding wire shall be effective;
- Wiring construction must be carried out by professional installation technicians according to the circuit diagram;
- Set up leakage protection devices according to the requirements of relevant national technical standards for electrical equipment;
- After all wiring work is completed, check carefully before switching on the power.

● Recommended power supply specifications

Model \ Project	Power supply	Wire diameter (mm ²)		Manual switch (A)		Leakage protector	Fuse (A)
		Dimensions (Continuous length ≤ 30m)	Grounding wire	Capacity	Fuse		
150L	220V-240V ~50Hz	≥ 2.5	≥ 2.5	30	25	30mA Below 0.1 sec	5
250L	220V-240V ~50Hz	≥ 2.5	≥ 2.5	30	25	30mA Below 0.1 sec	5

● Electrical schematic diagram

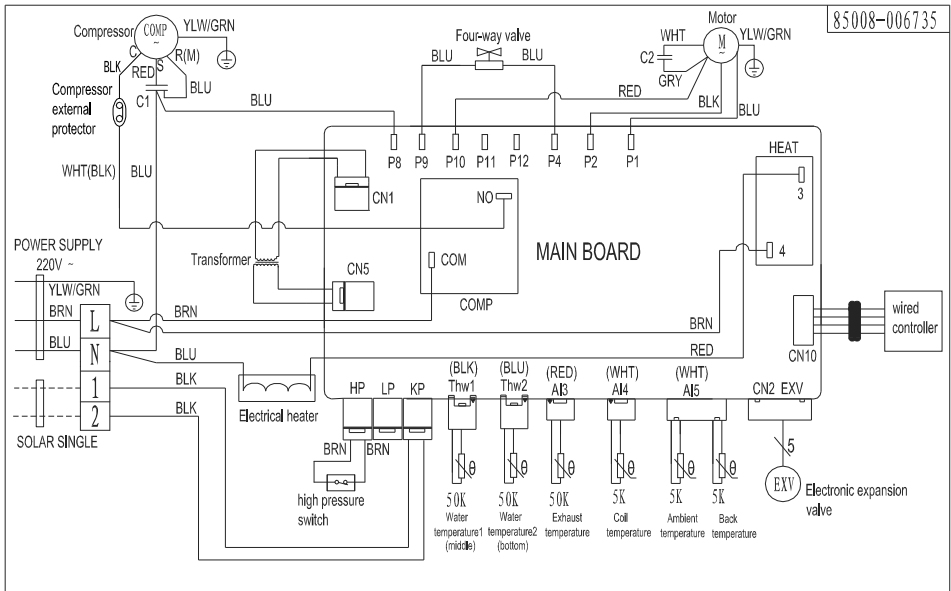

The wiring diagram of the unit is based on the actual unit.

Installation & Operation Manual

Usage Methods

When using, please operate by the following order:

Water affusion: When the unit is used for the first time(or the water tank is emptied and used again), the user must check that it has been filled with water before power-on. water affusion method(see the following figure)

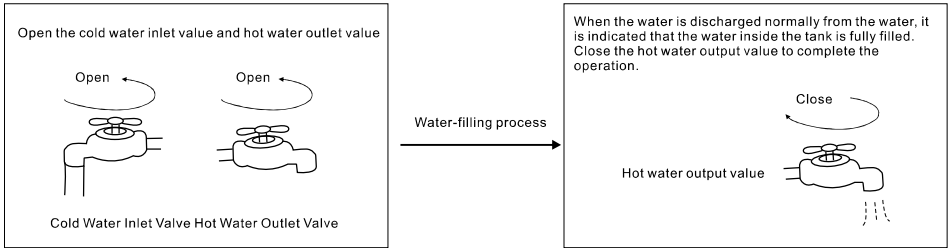

Warning

If an electric auxiliary heating unit is turned on when there is no water in the water tank, it will cause damage to the electric heating device.

- ② Turn on the power, the display screen lights up, indicating that the unit has been powered on. Users can switch different modes by pressing relevant keys on the display screen (see the next page for details)

Warning

If the water temperature exceeds 50°C, it may cause severe burns and even death. Children, the disabled and the elderly are at the highest risk of scalding. Please adjust to the proper water temperature first before bathing or using hot water.

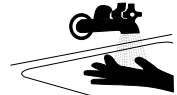

Water effusion: When cleaning and moving the machine, drain the water heater. Effusion method(see figure below)

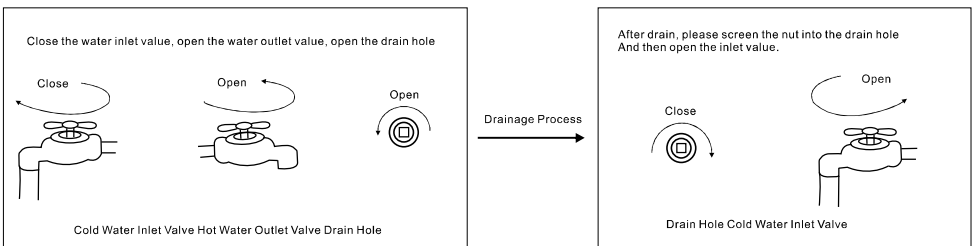





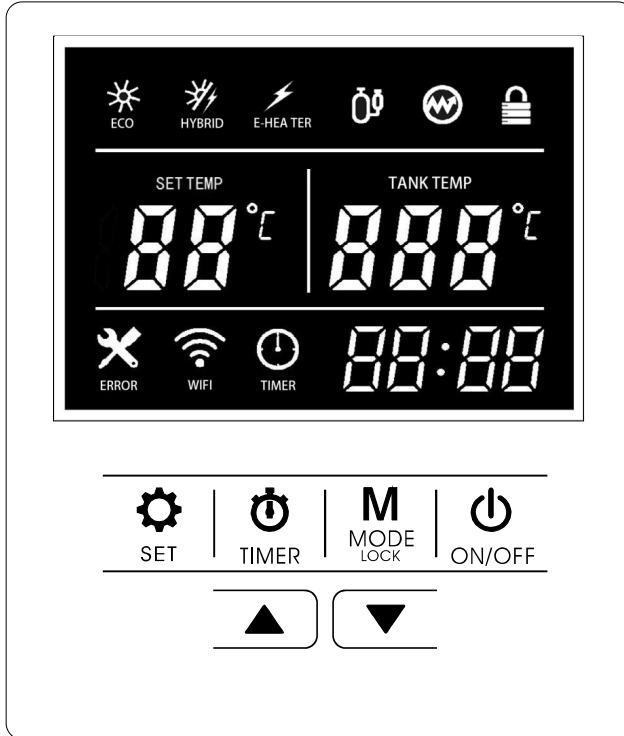







Operating Instructions

● Display screen and operation panel









● Display symbol description

NO	Description	NO	Description
1	 Economic mode	7	 Compressor state
2	 Hybrid heating mode	8	 Electric heating state
3	 Electric heating mode	9	 Child lock
4	 Setting temperature	10	 Tank temperature
5	 Fault state	11	 WIFI state
6	 Timing state	12	 Clock display

Installation & Operation Manual

● Descriptions of the keys

Key symbols	 ON/OFF	 MODE LOCK	 TIMER	 SET	 Temperature▲	 Temperature▼
Names	Turn on/off	Mode/lock	Timing	Setting	Temperature▲	Temperature▼

- After the unit is powered on, all symbols will be displayed on the display screen, and the normal pages will be displayed after waiting for 2 seconds.

1. key ON/OFF

In the standby state, press the "on/off" key once to perform the startup function and display the mode before the last shutdown;
In the start-up state, press the "on/off" key once to perform the shutdown function;
Press [temperature▲] key or [temperature▼] key to adjust the temperature of hot water, and the temperature increases or decreases by 1.0°C each time;
Press the [temperature▲] key or the [temperature▼] key for more than 3 seconds, and the temperature increases and decreases by 10°C;

- Key combination function, press "Settings" + "On/Off" at the same time and keep it for more than 3 seconds, then enter the WiFi distribution network function.

2. key MODE LOCK

(1) Mode conversion:

- In the start-up state, click the "Mode" key to switch modes in the following order, and the corresponding mode icons and characters are displayed on the display screen.



- Economic mode: The unit is set to economic mode, the hot water temperature is adjustable in the range of 30-60°C, the compressor is running at 30-60°C.
- Hybrid heating mode: The unit is set to hybrid heating mode, the hot water temperature is adjustable in the range of 30-70°C, the compressor and electric heating are running at 30-60°C, and the electric heating is running at 60-70°C.
- Electric heating mode: The unit is set to electric heating mode, the hot water temperature is adjustable in the range of 30-70°C, the electric heating will be operated in this range.
- The model with power-down memory, when powered on for the every time, will automatically enter the operation mode before power-down.

(2) Keyboard lock:

- When setting the child lock, press "Mode/Child Lock" for 3 seconds to lock up and release the child lock.

3. key TIMER

(1) Clock Setting

Press the "Timer" key for 3 seconds and then release to enter the time setting, and the hours and minutes in the time display area flash at the same time: press the "Timer" key again, and the hours in the time display area flash, and press the "up" key or "down" key to adjust the hours; Press the "clock" key again, and the minutes in the time display area flash. Press the "up" key or the "down" key to adjust the minutes; After the time setting, press the "Timer" key to save and exit.

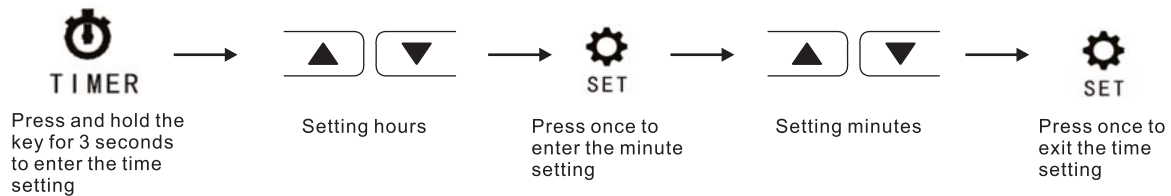

(2) Timer Startup

When there is no timing setting in the normal interface, press the "Timer" key once to enter the timed startup setting interface and timer symbol in the time area flashes, and "ON" is displayed in the temperature area of the water tank. The default time display is 00:00, and the hour area flashes. Press the "Setting" key to switch to the minute setting, and the minute area flashes. Then press the "Setting" key to switch to the timed shutdown setting.

(3) Timer Shutdown

The timer symbol in the time area flashes, and "OFF" is displayed in the temperature area of the water tank. The default time display is 00:00, and the hour area flashes. Press the "Setting" key to switch to the minute setting, and the minute area flashes. Then press the "Setting" key to save the timing setting.

(4) Cancel timing

When the timing is valid, press the "Timer" key once to cancel the timing.

Installation & Operation Manual

4. key

SET

- (1) The key is used in timed startup and timed shutdown setting, see the previous timing setting operation for details;
- (2) Press and hold the "Settings" key for 3 seconds to enter the parameter inquiry page. This function is mainly used for installation and maintenance of special personnel. See the following table for parameter details:

Code information	Number	Serial number	Remarks
Tank temperature 1 (Thw 1)		01	Unit: °C
Tank temperature 2 (Thw 1)		02	Unit: °C
Ambient temperature (Ten)		03	Unit: °C
Fin temperature (Tfr)		04	Unit: °C
Compressor exhaust temperature (Tcomp)		05	Unit: °C
Return temperature (Tba)		06	Unit: °C
Current of compressor		07	Unit: A
Current opening of electronic expansion valve		08	Unit: Step
Set mode		09	00: Economic heating; 01: Hybrid heating; 02: Electric heating
Heating set temperature (Ts)		10	Unit: °C
Display water temperature		11	Unit: °C
Controller version number		12	Example: A05
Display version number		13	Example: A01
Jumper cap setting model number		14	Examples: 01, 02, 03
Last fault code		15	Example: E1
Second last fault code		16	Example: E1
Third last fault code		17	Example: E1
Fourth last fault code		18	Example: E1

5. key

1. "Temperature▲": The set temperature is increased by 1.0°C
2. "Temperature▼": the set temperature is decreased by 1.0°C
3. During operation, press " [▲] → [▼] → [▲] → [▼] → [▲] → [▼] "continuously within 5 seconds (press the key 6 times in total), and then execute the forced defrosting.
4. When the unit is shut down, set the temperature in the range of 30 °C~33 °C, and press " [▲] → [▼] → [▲] → [▼] → [▲] → [▼] "within 5 seconds (press the key 6 times in total), and then execute the manual fluorine collection.

Trial Operation

Please confirm the following matters before trial operation:

1. Whether the unit is installed correctly;
2. Whether the piping and wiring are correct;
3. Whether the drainage is smooth;
4. Whether the insulation is well done;
5. Whether the grounding wires are correctly connected;
6. Whether the power supply voltage is equal to the rated voltage of the water heater;
7. Whether there are obstacles at the air inlet and outlet;
8. Whether the air in the water pipeline is emptied, and all valves opened;
9. Whether the leakage protector can be operated effectively;
10. Whether the inlet water pressure is not less than 0.15 MPa.

Maintenance and Troubleshooting

Maintenance

The water heater has high level degree of automation, it is necessary to check the unit regularly.

If the unit can be effectively maintained for a long time, the operating reliability and service life of the unit will be significantly improved.

1. The water filter installed outside the machine shall be cleaned regularly to ensure the clean water quality in the system, so as to avoid the damage caused by dirty water filter.
2. During using and maintaining the unit, the users shall make sure that all safety protection devices in the unit have been properly set before leaving the factory. Do not adjust the unit by yourself.
3. Always check whether the wiring of the power supply and electrical system is firmly connected, and whether the electrical components have abnormal actions. If so, they shall be repaired and replaced in time.
4. Always check whether the water supply solenoid valve of the water system, the safety valve of the water tank, the liquid level controller and the exhaust device work normally, so as to avoid the reduction of water circulation caused by air entering the system, thus affecting the heating capacity of the unit and the reliability of the unit operation.
5. Check whether the water pump and waterway valves work normally, and whether the water pipeline and joints leak.
6. The surroundings of the unit shall be kept clean, dry and well ventilated. Clean the air-side heat exchanger regularly (usually from January to February) to maintain good heat transfer effect.
7. Always check the working conditions of various parts of the unit, and check whether there is oil contamination at the pipeline joints and inflation valves in the unit to ensure that there is no leakage of refrigerant in the unit.
8. The surroundings of the unit shall be kept clean and dry, and well ventilated to avoid blocking the air inlet and outlet.
9. If the unit is unused for a long time, the water in the pipeline of the unit shall be drained, the power supply shall be switched off, and the protective cover shall be set. Comprehensive inspection of the system shall be done before next start-up.
10. When the unit is failed and the user can't solve the problem, please call the local authorized service shop of our company to repair it in time.

Installation & Operation Manual

11. Cleaning of main engine condenser. It is recommended to clean the condenser with hot phosphoric acid solution at 50°C-60°C and concentration of 15%. When installing the pipeline, it is recommended to reserve a three-way interface and seal one interface with a plug for connecting additional pipe during cleaning. It is forbidden to clean the condenser with corrosive cleaning solution.
12. After the water tank is used for a period of time (generally one month, depending on the local water quality), it is necessary to remove the scale and discharge the sewage regularly.
13. Check and make sure that the power plug and socket are well fit, well grounded and free from overheating.
14. If it is unused for a long time, especially in areas with low temperature (lower than 0 °C), in order to prevent the water in the inner tank from freezing and causing damage to the water tank, the water in the water tank shall be discharged.
15. In order to ensure the long-term efficient operation of the water heater, it is recommended to thoroughly drain and flush the water tank every six months to remove the sediment that may accumulate during operation.
16. The water tank is equipped with a magnesium rod to protect the inner container from corrosion and prolong the service life of the water tank. In this process, the magnesium rod is also slowly consumed. In some water environments, magnesium rods react with water. Once magnesium rods are consumed, the tank liner begins to corrode and eventually causes leakage. It is recommended to check the magnesium rod every year or so. If it is consumed, please replace it with a new magnesium rod. For details, please consult the local air conditioning customer service center or the authorized service shop.
17. If hot water is sufficient, it is recommended that users lower the set temperature, which can reduce heat loss and scale generation, save electric energy and prolong the service life of the water heater.
18. When the ambient temperature is lower than 0°C and the water tank is installed outdoors, please take insulation measures for the water inlet and outlet pipes. If necessary, please install pipeline heating devices to avoid freezing the pipelines.

If the unit is equipped with a filter screen, it is necessary to clean the filter screen by the following instructions:

1. Unscrew the top screw of the unit and unscrew the upper cover counterclockwise;
2. Remove the upper cover and pull out the filter screen;
3. After cleaning the filter screen, dry completely and put it back.

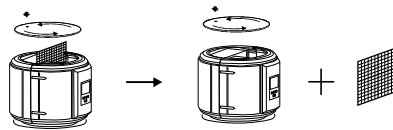

SLA-R20-250/N3A4

Guidelines for replacing anode protection rods

1. Turn off the power supply of the water heater and the cold water inlet valve;
2. Open the hot water faucet to reduce the pressure of the inner;
3. Open the drain outlet and discharge about 50L of water. Remove the magnesium rod;
4. Replace with a new anode protection rod and tighten it to ensure reliable sealing, please find the Magnesium Rod replace Instructions on page 18 for detailed steps to remove the magnesium rod;
5. Open the cold water inlet valve until water flows out of the hot water faucet, and close the hot water faucet;
6. Turn on the power supply for normal operation.

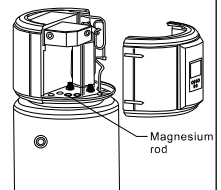

● Troubleshooting

Faults	Causes	Troubleshooting
Cold water flows out. The display screen does not light up	1. The power plug is not plugged in; 2. The thermostat is in minimum temperature control state 3. The thermostat is damaged; 4. The indicator lamp circuit board is damaged;	1. Plug in the power plug; 2. Adjust the temperature of the thermostat to a higher state; 3. Notify the maintenance personnel;
No water out of the hot water outlet	1. Tap water supply is cut off; 2. The water pressure is too low; 3. The tap water inlet valve is not opened;	1. Wait for tap water supply to be recovered; 2. Reuse when the water pressure rises; 3. Open the tap water inlet valve;
Leaking water	Poor seal at the pipe joints	Seal the pipe joints

When the machine fails and cannot run, the "Fault" icon on the display screen lights up, and the setting temperature zone displays the current fault code:

Display content	Definition of faults or protections	Display content	Definition of faults or protections
E1	Thw1 fault of hot water temperature sensor	E0	Parameter error fault
E2	High voltage fault	EA	High temperature protection of exhaust of compressor
E3	Tfr fault of fin temperature sensor	ED	Antifreeze protection
E4	Ten fault of ambient temperature sensor	ET	The ambient temperature is not in the operating range of the heat pump
E5	Tba fault of return air temperature sensor		
E6	Tcom fault of exhaust temperature sensor	EE	Excessive running current of compressor
E7	Low pressure protection	EB	Two low current of compressor
E8	Thw2 fault of Hot water temperature sensor	EF	Communication fail

Other display codes, not faults

Display content	Definition	Display content	Definition
DEF	During defrosting, remind users that is in the defrosting process	FRE	In antifreezing, prevent the temperature of the water tank from being too low
CF	Refrigerant recovery	SP	The unit is in the non-municipal power supply state
DIS	Automatic sterilization		

Automatic sterilization function

Intelligently detects the temperature of the water tank, automatically enters the sterilization function (display panel displays [DIS]) when the conditions are met, the mode is changed to Hybrid heating mode, and the set temperature is changed to 70 °C; when the conditions for exiting the sterilization function are met, the sterilization function is automatically exited and normal operation is restored.

If you want to turn off the automatic sterilization function, in the shutdown state, press and hold the [SET]+[▼] key for 3 seconds to enter the parameter setting page, and use the [▲] or [▼] key to select the parameter to the serial number [26], Press the [SET] key to enter the setting, and change the [ON] to [OFF] to complete the function off. If the automatic sterilization function is turned on again, you only need to set the parameter to [ON] to turn it on again (do not change other parameters).

● Replace magnesian stick

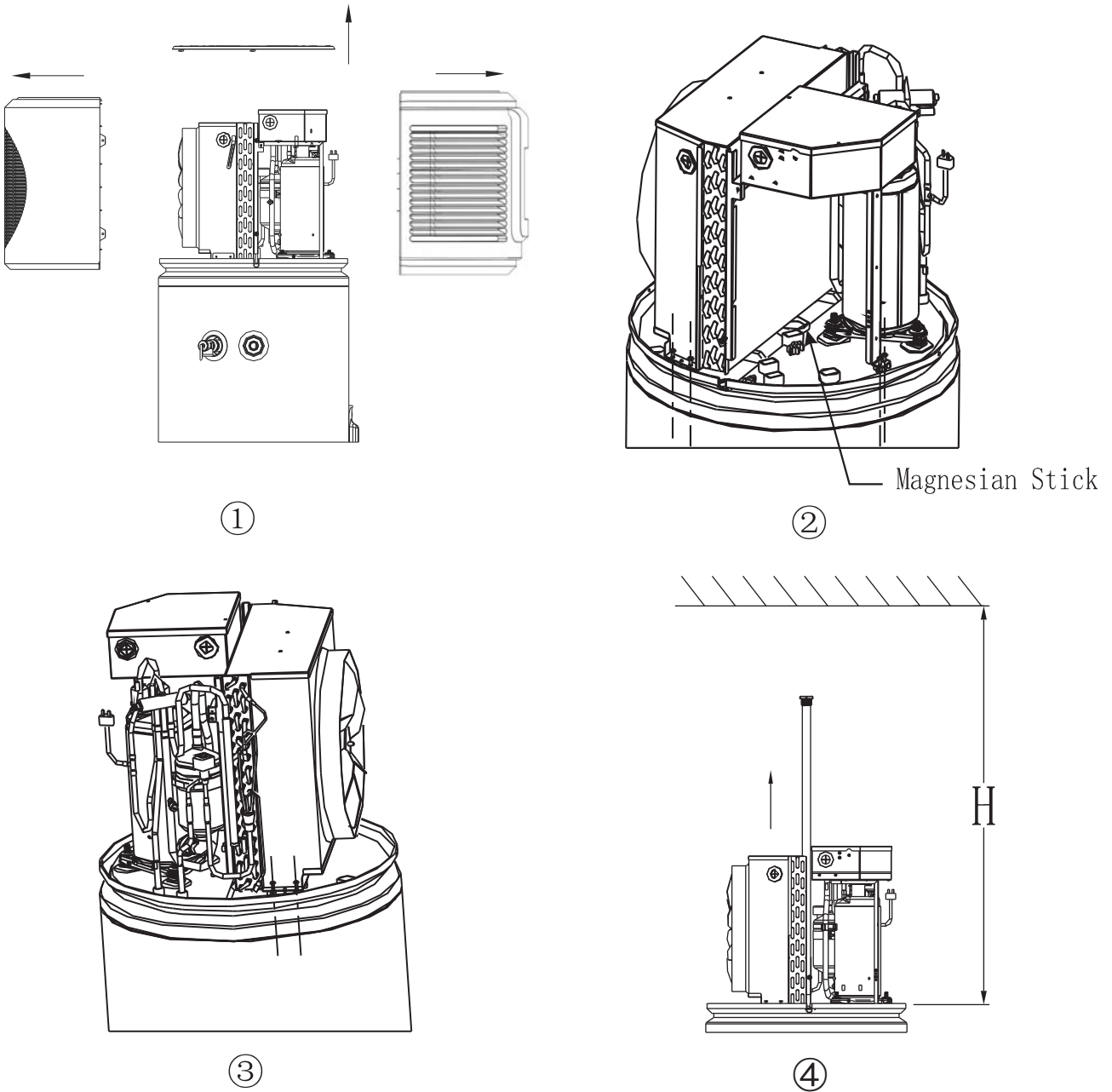

Model	KZd40-RS250T/ED-3
Parameter	
H	≥1450

1. Remove the screws on the top and side of the water heater and the cable connecting the display screen, and remove the top cover as shown in figure ①.
2. Remove the fixing screws of the electric control box on the water pan, move the electric control box slowly, and find the position of the magnesium rod, to be note that use a special socket wrench to disassemble and assemble the magnesium rod, as shown in Figure ②.
If the magnesium rod is under the evaporator, remove the 4 screws of the air outlet frame assembly on the water pan and 2 fixing screw of the electric control box on the water pan, move the air outlet frame assembly backward slowly until the magnesium rod is visible, and then use a special socket wrench to remove and replace the magnesium rod, as shown in figure ③;
3. When lifting out the magnesian stick, please ensure that the H distance as shown in Figure ④.

● Power cord installation:

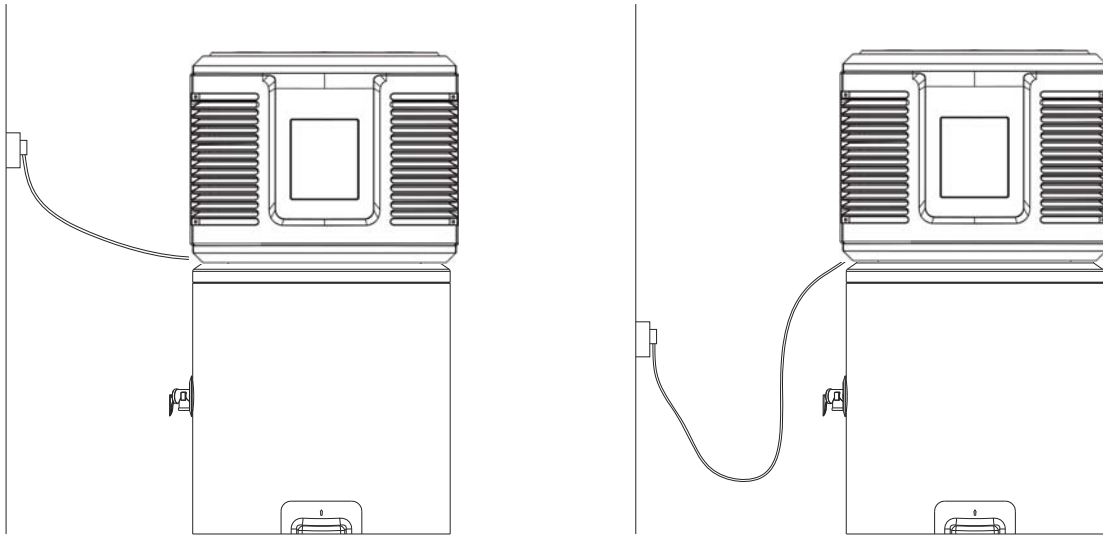

The height of the power socket must be higher than the line outlet of the power line, Otherwise a certain length of the power line needs to be reserved to block the ponding.
(As shown in figure)

When your water heater is not working properly, immediately shut down and cut off the power supply, and then contact the local technical service department.

