

Smart LifestyleTM

A U S T R A L I A

INSTALLATION AND USER MANUAL

Air to Water Heat Pump Water Heater

All-in-one type



R290

Natural Refrigerant
Excellent Efficiency
Low GWP

SLA-R20-190D/N4A4

SLA-R25-250D/N4D4

SLA-R25-300D/N4D4

SMART LIFESTYLE AUSTRALIA PTY LTD

Email: service@smartlifestyleaustralia.com.au

Thank you very much for purchasing our product.
Please read this manual carefully before operating the unit.



Propane
(R290)

**IMPORTANT: RISK OF FIRE OR EXPLOSION!
FLAMMABLE REFRIGERANT USED.**

- Place in well ventilated area to prevent accumulation of refrigerant.
- Repair and disposal must be carried out by trained service personnel.
- No naked flame during servicing or repair.

WARNING



Installation to conform with AS/NZS 3500.4

WARNING



The heat pump unit requires a reliable earthing connection before usage; otherwise it might cause death or injury.



If you cannot confirm that your house power supply is earthed well, please do not install the unit before carefully check it. Please have a qualified person to check the reliable earthing connection and install the unit.

Examples of a qualified person include: Licensed plumbers, Authorized electric company personnel, and Authorized service personnel.



WARNING

- IF THE HOT WATER SYSTEM IS NOT USED FOR TWO WEEKS OR MORE, A QUANTITY OF HIGHLY FLAMMABLE HYDROGEN GAS MAY ACCUMULATE IN THE WATER HEATER. TO DISSIPATE THIS GAS SAFELY, IT IS RECOMMENDED THAT A HOT TAP BE TURNED ON FOR SEVERAL MINUTES OR UNTIL DISCHARGE OF GAS CEASES. USE A SINK, BASIN, OR BATH OUTLET, BUT NOT A DISHWASHER, CLOTHES WASHER, OR OTHER APPLIANCE. DURING THISPROCEDURE, THERE MUST BE NO SMOKING, OPEN FLAME, OR ANY ELECTRICAL APPLIANCE OPERATING NEARBY. IF HYDROGEN IS DISCHARGED THROUGH THE TAP, IT WILL PROBABLY MAKE AN UNUSUAL SOUND AS WITH AIR ESCAPING.
- WARNING - THIS APPLIANCE MAY DELIVER WATER AT A HIGH TEMPERATURE. REFER TO THE PLUMBING CODE OF AUSTRALIA (PCA), LOCAL REQUIREMENTS AND INSTALLATION INSTRUCTIONS TO DETERMINE IF ADDITIONAL TEMPERATURE CONTROL IS REQUIRED.
- WARNING - FOR CONTINUED SAFETY OF THIS APPLIANCE IT MUST BE INSTALLED, OPERATED AND MAINTAINED IN ACCORDANCE WITH THE MANUFACTURER'S INSTRUCTIONS.

Notes:

In this manual,

- Model No. SLA-R18-190*** includes total 3 model numbers: SLA-R18-190D/N4A4, SLA-R18-190D/N4A4C/70-2 and SLA-R18-190D/N4A4C/70-5.
- Model No. SLA-R25-250*** includes total 3 model numbers: SLA-R25-250D/N4D4, SLA-R25-250D/N4D4C/70-2 and SLA-R25-250D/N4D4C/70-5.
- Model No. SLA-R25-300*** includes total 3 model numbers: SLA-R25-300D/N4D4, SLA-R25-300D/N4D4C/70-2 and SLA-R25-300D/N4D4C/70-5.



WARNING

- Hose-set is not to be used.
- DANGER: The operation of the thermal cut-out indicates a possibly dangerous situation. Do not reset the thermal cut-out until the water heater has been serviced by a qualified person.
- DANGER: Failure to operate the relief valve easing gear at least once every six months may result in the water heater exploding. Continuous leakage of water from the valve may indicate a problem with the water heater.
- If the water supply pressure exceeds the rated pressure, a pressure reducing valve is to be fitted in the installation.
- Before leave unused for a long time, please complete the following items:
 - Open the pipe orifice and drain water from water tank.
 - Further advice. Arrange drainpipes to ensure efficient drainage. Improper drainage can cause water damage to surrounding areas such as buildings, furniture, etc.

-
- Do not use means to accelerate the defrosting process or to Clean, other than those recommended by the manufacturer.
 - The appliance shall be stored in a room without continuously operating ignition sources (For example: open flames, an operating gas appliance or an operating electric heater). Do not pierce or burn.
 - Be aware that refrigerants may not contain an odor.
NOTE: The manufacturer may provide other suitable examples or may provide additional information about the refrigerant odor.



Propane
(R290)

SERVICING INFORMATION

- Checks to the area
Prior to beginning work on systems containing flammable refrigerants, safety checks are necessary to ensure that the risk of ignition is minimized. For repair to the refrigerating system, the following precautions shall be complied with prior to conducting work on the system.
- Work procedure
Works shall be undertaken under a controlled procedure so as to minimize the risk of a flammable gas or vapour being present while the work is being performed.
- General work area
All maintenance staff and others working in the local area shall be instructed on the nature of work being carried out. Work in confined spaces shall be avoided. The area around the work space shall be sectioned off. Ensure that the conditions within the area have been made safe by control of flammable material.
- Checking for presence of refrigerant
The area shall be checked with an appropriate refrigerant detector prior to and during work, to ensure the technician is aware of potentially flammable atmospheres. Ensure that the leak detection equipment being used is suitable for use with flammable refrigerants, i.e. no sparking, adequately sealed or intrinsically safe.
- Presence of fire extinguisher
if any hot work is to be conducted on the refrigeration equipment or any associated parts, appropriate fire extinguishing equipment shall be available to hand. Have a dry power or CO2 fire extinguisher adjacent to the charging area.

-
- No ignition sources
No person carrying out work in relation to a refrigeration system which involves exposing any pipe work that contains or has contained flammable refrigerant shall use any sources of ignition in such a manner that it may lead to the risk of fire or explosion.
 - All possible ignition sources, including cigarette smoking, should be kept sufficiently far away from the site of installation, repairing, removing and disposal, during which flammable refrigerant can possibly be released to the surrounding space. Prior to work taking place, the area around the equipment is to be surveyed to make sure that there are no flammable hazards or ignition risks. NO SMOKING sign shall be displayed.
 - Ventilated area conducting any hot work.
Ensure that the area is in the open or that it is adequately ventilated before breaking into the system or conducting any hot work.
A degree of ventilation shall continue during the period that the work is carried out, The ventilation should safely disperse any released refrigerant and preferably expel it externally into the atmosphere.
 - Checks to the refrigeration equipment
Where electrical components are being changed, they shall be fit for the purpose and to the correct specification. At all times the manufacturer's maintenance and service guidelines shall be followed. If in doubt consult the manufacturer's technical department for assistance. The following checks shall be applied to installations using flammable refrigerants.
 - Checks to electrical devices
Repair and maintenance to electrical components shall include initial safety checks and component inspection procedures. If a fault exists that could compromise safety, then no electrical supply shall be connected to the circuit until it is satisfactorily dealt with. If the fault cannot be corrected immediately but it is necessary to continue operation, an adequate temporary solution shall be used, This shall be reported to the owner of the equipment so all parties are advised.
 - Initial safety checks shall include:
The charge size is in accordance with the room size within which the refrigerant containing parts are installed
The ventilation machinery and outlets are operating adequately and are not obstructed.
If an indirect refrigerating circuit is being used, the secondary circuits shall be checked for the presence of refrigerant; marking to the equipment continues to be visible and legible.
Marking and signs that are illegible shall be corrected.
 - Refrigeration pipe or components are installed in a position where they are unlikely to be exposed to any substance which may corrode refrigerant containing components, unless the components are constructed of materials which are inherently resistant to being corroded or are suitably protected against being so corroded.
That capacitors are discharged: this shall be done in a safe manner to avoid possibility of sparking. That there are no live electrical components and wiring are exposed while charging, recovering or purging the system.
That there is continuity of earth bonding.
 - Repairs to sealed components
Ensure that apparatus is mounted securely.
Ensure that seals or sealing materials have not degraded such that they no longer serve the purpose of preventing the ingress of flammable atmospheres. Replacement parts shall be in accordance with the manufacturer's specifications.

-
- Repair to intrinsically safe components
Do not apply any permanent inductive or capacitance loads to the circuit without ensuring that this will not exceed the permissible voltage and current permitted for the equipment in use. intrinsically safe components are the only types that can be worked on while live in the presence of a flammable atmosphere. The test apparatus shall be at the correct rating. Replace components only with parts specified by the manufacturer Other parts may result in the ignition of refrigerant in the atmosphere from a leak.
 - Cabling
Check that cabling will not be subject to wear, corrosion, excessive pressure, vibration, sharp edges or any other adverse environmental effects, The check shall also take into account the effects of aging or continual vibration from sources such as compressors or fans.
 - Detection of flammable refrigerants
Under no circumstances shall potential sources of ignition be used in the searching for or detection of refrigerant leaks. A halide torch (or any other detector using a naked flame) shall not be used.
 - Leak detection methods
The following leak detection methods are deemed acceptable for systems containing flammable refrigerants. Electronic leak detectors shall be used to detect flammable refrigerants, but the sensitivity may not be adequate, or may need re-calibration. (Detection equipment shall be calibrated in a refrigerant-free area.) Ensure that the detector is not a potential source of ignition and is suitable for the refrigerant. Leak detection equipment shall be set at a percentage of the LFL of the refrigerant and shall be calibrated to the refrigerant employed and the appropriate percentage of gas (25% maximum) is confirmed. Leak detection fluids are suitable for use with most refrigerants but the use of detergents containing chlorine shall be avoided as the chlorine may react with the refrigerant and corrode the copper pipe-work. If a leak is suspected, all naked flames shall be removed or extinguished. If a leakage of refrigerant is found which requires brazing, all of the refrigerant shall be recovered from the system, or isolated (by means of shut off valves) in a part of the system remoter from the leak. Oxygen free nitrogen (OFN) shall then be purged through the system both before and during the brazing process.
 - Removal and evacuation
When breaking into the refrigerant circuit to make repairs of for any other purpose conventional procedures shall be used, however, it is important that best practice is followed since flammability is a consideration. The following procedure shall be adhered to:
Remove refrigerant;
Purge the circuit with inert gas;
Evacuate;
Purge again with inert gas;
Open the circuit by cutting or brazing.
The use of silicon sealant may inhibit the effectiveness of some types of leak detection equipment.
Intrinsically safe components do not have to be isolated prior to working on them.
 - NOTE
The refrigerant charge shall be recovered into the correct recovery cylinders. The system shall be flushed with OFN to render the unit safe. This process may need to be repeated several times. Compressed air or oxygen shall not be used for this task. Flushing shall be achieved by breaking the vacuum in the system with OFN and continuing to fill until the working pressure is achieved, then venting to atmosphere, and finally pulling down to a vacuum. This process shall be repeated until no refrigerant is within the system. When the final OFN charge is used, the system shall be vented down to atmospheric pressure to enable work to take place. This operation is absolutely vital if brazing operations on the pipe-work are to take place. Ensure that the outlet for the vacuum pump is not closed to any ignition sources and there is ventilation available.
-

- Charging procedures

In addition to conventional charging procedures, the following requirements shall be followed:

Ensure that contamination of different refrigerants does not occur when using charging equipment.

Hoses or lines shall be as short as possible to minimize the amount of refrigerant contained in them.

Cylinders shall be kept upright.

Ensure that the refrigeration system is earthed prior to charging the system with refrigerant.

Label the system when charging is complete (if not already).

Extreme care shall be taken not to overfill the refrigeration system.

Prior to recharging the system it shall be pressure tested with OFN. The system shall be leak tested on completion of charging but prior to commissioning. A follow up leak test shall be carried out prior to leaving the site.

- Decommissioning

Before carrying out this procedure, it is essential that the technician is completely familiar with the equipment and all its detail.

It is recommended good practice that all refrigerants are recovered safely. Prior to the task being carried out, an oil and refrigerant sample shall be taken.

In case analysis is required prior to re-use of reclaimed refrigerant. It is essential that electrical power is available before the task is commenced.

a) Become familiar with the equipment and its operation.

b) Isolate system electrically

c) Before attempting the procedure ensure that:

Mechanical handling equipment is available, if required, for handling refrigerant cylinders.

All personal protective equipment is available and being used correctly.

The recovery process is supervised at all times by a competent person. Recovery equipment and cylinders conform to the appropriate standards.

d) Pump down refrigerant system, if possible

e) If a vacuum is not possible, make a manifold so that refrigerant can be removed from various parts of the system.

f) Make sure that cylinder is situated on the scales before recovery takes place.

g) Start the recovery machine and operate in accordance with manufacturer's instructions.

h) Do not overfill cylinders. (No more than 80% volume liquid charge).

i) Do not exceed the maximum working pressure of the cylinder, even temporarily.

j) When the cylinders have been filled correctly and the process completed, make sure that the cylinders and the equipment are removed from site promptly and all isolation valves on the equipment are closed off.

k) Recovered refrigerant shall not be charged into another refrigeration system, unless it has been cleaned and checked.

- Labeling

Equipment shall be labeled stating that it has been de-commissioned and emptied of refrigerant. The label shall be dated and signed. Ensure that there are labels on the equipment stating the equipment contains flammable refrigerant.

- Recovery

When removing refrigerant from a system, either for service or decommissioning, it is recommended good practice that all refrigerants are removed safely.

When transferring refrigerant into cylinders, ensure that only appropriate refrigerant recovery cylinders are employed. Ensure that the correct numbers of cylinders for holding the total system charge are available. All cylinders to be used are designated for the recovered refrigerant and labeled for that refrigerant (i.e. special cylinders for the recovery of refrigerant). Cylinders shall be complete with pressure relief valve and associated shut-off valves in good working order. Empty recovery cylinders are evacuated and, if possible, cooled before recovery occurs.

The recovery equipment shall be in good working order with a set of instructions concerning the equipment that is at hand and shall be suitable for the recovery of flammable refrigerants, In addition, a set of calibrated weighing scales shall be available and in good working order.

Hoses shall be complete with leak-free disconnect couplings and in good condition. Before using the recovery machine, check that it is in satisfactory working order, has been properly maintained and that any associated electrical components are sealed to prevent ignition in the event of a refrigerant release. Consult manufacturer if in doubt.

The recovered refrigerant shall be returned to the refrigerant supplier in the correct recovery cylinder, and the relevant Waste Transfer Note arranged. Do not mix refrigerants in recovery units and especially not in cylinders. If compressors or compressor oils are to be removed, ensure that they have been evacuated to an acceptable level to make certain that flammable refrigerant does not remain within the lubricant. The evacuation process shall be carried out prior to returning the compressor to the suppliers. Only electric heating to the compressor body shall be employed to accelerate this process. When oil is drained from a system, it shall be carried out safely.

- Transportation, marking and storage for units

Transport of equipment containing flammable refrigerants Compliance with the transport regulations. Marking of equipment using signs. Compliance with local regulations.

Disposal of equipment using flammable refrigerants Compliance with national regulations.

Storage of equipment/appliances.

The storage of equipment should be in accordance with the manufacturer's instructions.

Storage of packed (unsold) equipment.

Storage package protection should be constructed such that mechanical damage to the equipment inside the package will not cause a leak of the refrigerant charge.

The maximum number of pieces of equipment permitted to be stored together will be determined by local regulations.

Part names:

SLA-R18-190D***

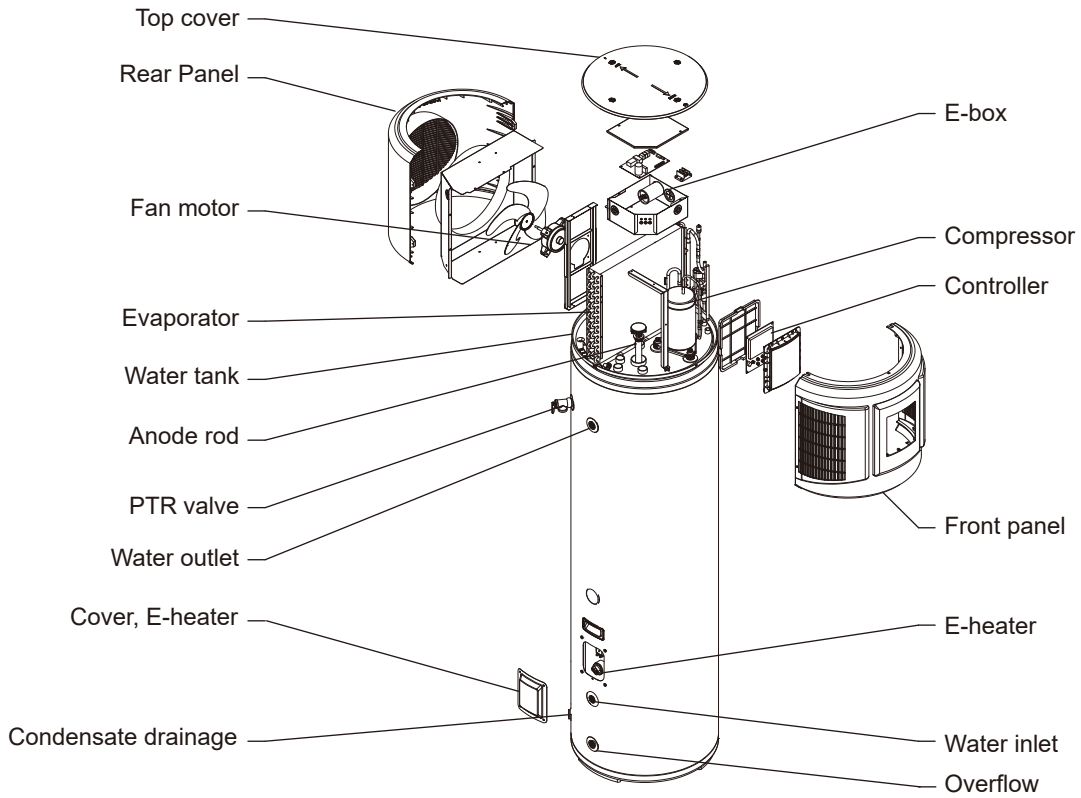

SLA-R25-250*, SLA-R25-300*****

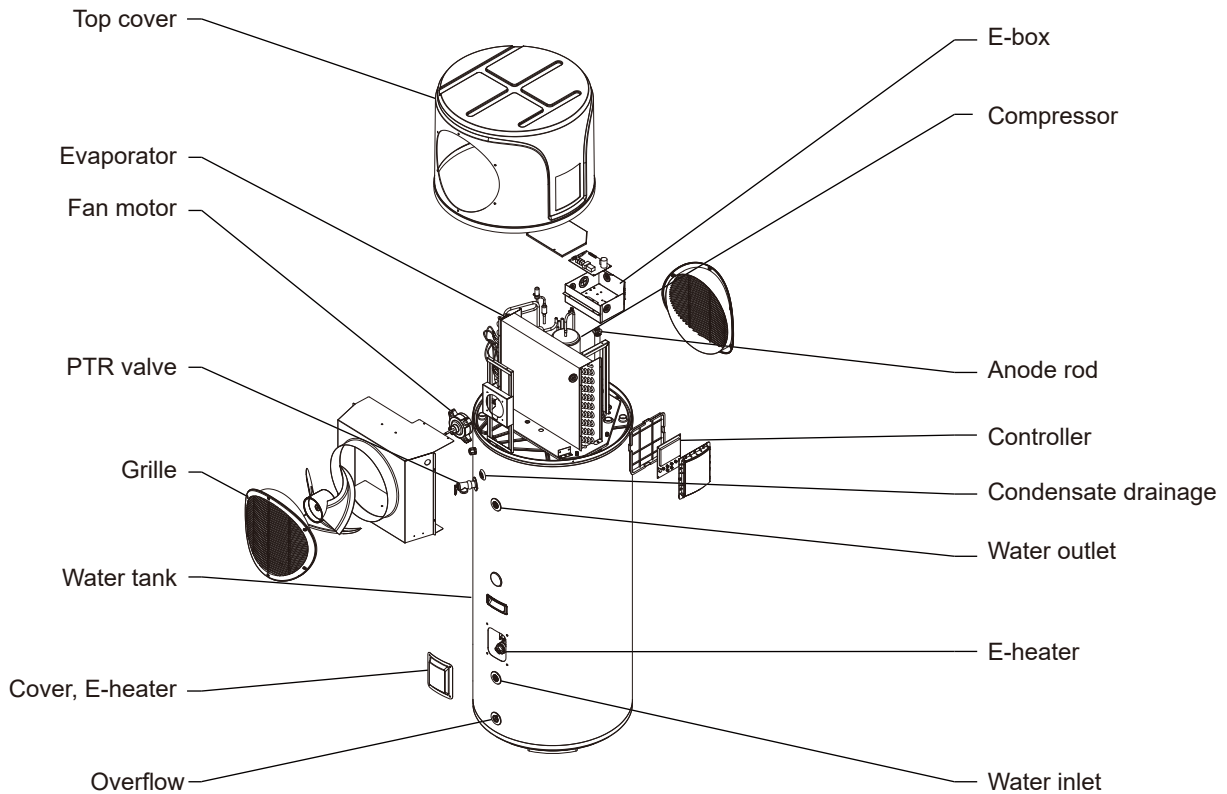



Contents	Pages
1. Safety information	01
2. Preparation of installation	04
3. Installations	07
4. Trial-running	20
5. Operation	21
6. Troubleshooting	29
7. Maintenance	32
8. Specifications	33

1. Safety information

Please carefully read thoroughly all of the instructions before installing or operating the unit.

Following safety symbols are very important, please carefully read and always obey all safety symbols.

 CAUTION	If the precaution is not taken, it may cause minor or moderate injury
 WARNING	If the warning is not heeded, it can cause death or serious injury.
 DANGER	If the danger is not avoided, it will cause death or serious injury



WARNING

- For stationary appliances permanently connected to the fixed wiring, compliance with this requirement is considered to be met if the instruction concerning disconnection incorporated in the fixed wiring is in accordance with AS/NZS 3000.
- The unit must be earthed effectively and reliably.
- A residual current operated circuit-breaker (RCCB) must be installed adjacent to the power supply.
- Do not remove, cover or deface any permanent instructions, labels or the data labels from either the outside of the unit or inside of unit panels.
- Only the qualified person can perform the installation of this unit in accordance with local national regulations and this installation manual. Improper installation may result in water leakage, electric shock or fire.
- Only the qualified person can relocate, repair and maintain the unit. Improper installation and repairing may result in water leakage, electric shock or fire.
- Electric connection work should obey the instructions of local power company, local electric utility and this manual.
- Never use the wire and fuse with wrong rated current, otherwise unit may breakdown and cause fire furthermore.
- Do not insert fingers, rods or other objects into the air inlet or outlet. When the fan is rotating at high speed, it will cause injury.
- Never use a flammable spray such as hair spray, lacquer paint near the unit, because it may cause a fire.
- The heat pump unit is not intended for use by persons (including children) with reduced physical, sensory or mental capabilities, or lack of experience and knowledge, unless they have been given supervision or instruction concerning use of the unit by a person responsible for their safety. Children should be supervised to ensure that they do not play with the unit.
- Once the power supply cord is damaged, it must be replaced by service agent or the manufacturer or a similarly qualified person.
- Do not dispose this unit as unsorted municipal waste. Collection of such waste separately for special treatment is necessary.





Do not dispose of electrical appliances as unsorted municipal waste, use separate collection facilities. Please contact local government for information regarding the collection systems available.

If electrical appliances are disposed of the landfills or dumps, hazardous substances can leak into the groundwater and get into the food chain, damaging your health and well-being.



CAUTION

- The ground wire's pole of socket must be grounded well, make sure that power supply socket and plug are dry and connected well.
- To check the power supply socket and plug are qualified -
Step 1: Turn on the power supply.
Step 2: Keep the unit running for a half hour.
Step 3: Turn off the power supply and plug out.
Step 4: Check whether the socket and plug is hot or not.
- Before cleaning, be sure to stop the operation and turn the breaker off or pull out the power supply plug. Otherwise, an electric shock and injury may be caused.
- Produced hot water temperature can reach over 50°C. It can cause severe burns instantly or death form scalds. Children, disabled and elderly persons are at highest risk of being scalded. Feel water is necessary before bathing or showering. So, water temperature limiting valves are recommended.

 CAUTIONS	
	Very hot water. Burns or injury may occur.

- Do not operate the unit with a wet hand; otherwise, an electric shock may be caused.
 - The installation height of power supply should be over 1.8m, if there is any water spattered, separate the power supply from water.
 - It is normal if some water drops from the hole of PTR valve during operation. But if there is a great amount of water, call the service agent for instruction.
After a long term use, check the unit base and fittings. If damaged, the unit may sink and result in injury.
 - Arrange the drain pipe to ensure smooth draining. Improper drainage work may cause wetting of the building, furniture, etc.
 - Do not touch the inner parts of the controller. Do not remove the front panel. Some parts inside are dangerous to touch, otherwise the unit malfunction may be caused.
 - Do not turn off the power supply. System will stop or restart heating automatically during the standby mode. A continuous power supply for the unit is necessary, except service and maintenance.
 - If the unit has not been used for a long period of time (2 weeks or more), hydrogen gas will be produced in the water piping system.
 - Hydrogen gas is extremely flammable. To reduce the risk of injury under these conditions, it is recommended that open the hot water tap for several minutes at the kitchen sink before using any electrical appliance connected to the hot water system. When hydrogen is present, there will probably be an unusual sound such as air escaping through the pipe as the water begins to flow. There should be no smoking or open flame near the tap at the time it is open.
-



The refrigerant Appliance filled with flammable gas R290.



Before install the appliance, read the installation manual first.

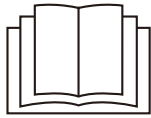

Before use the appliance, read the owner's manual first.



Before repair the appliance, read the service manual first.

To realize the function of the air conditioner unit, a special refrigerant circulates in the system. The used refrigerant is the fluoride R290, which is specially cleaned. The refrigerant is flammable and inodorous. Furthermore, it can lead to explosion under certain conditions. But the flammability of the refrigerant is very low. It can be ignited only by fire.

To realize the function of the air conditioner unit, a special refrigerant circulates in the system. The used refrigerant is the fluoride R290, which is specially cleaned. The refrigerant is flammable and inodorous. Furthermore, it can lead to explosion under certain conditions. But the flammability of the refrigerant is very low. It can be ignited only by fire.



WARNING

Do not use means to accelerate the defrosting process or to clean, other than those recommended by the manufacture. Should repair be necessary, contact your nearest authorized Service Centre. Any repairs carried out by unqualified personnel may be dangerous. The appliance shall be stored in a room without continuously operating ignition sources. (for example: open flames, an operating gas appliance or an operating electric heater.) Do not pierce or burn. Appliance shall be installed, operated and stored so as to be fitted in the installation.

Appliance filled with flammable gas R290. For repairs, strictly follow manufacturer's instructions only. Be aware that refrigerants may not contain an odour. Read specialist's manual.



Propane
(R290)



Qualification requirement for installation and maintenance man

All the work men who are engaging in the refrigeration system should bear the valid certification awarded by the authoritative organization and the qualification for dealing with the refrigeration system recognized by this industry. If it needs other technician to maintain and repair the appliance, they should be supervised by the person who bears the qualification for using the flammable refrigerant.

It can only be repaired by the method suggested by the equipment's manufacturer.

Maintenance notes

Check whether the maintenance area or the room area meet the requirement of the nameplate.

- It's only allowed to be operated in the rooms that meet the requirement of the nameplate.

Check whether the maintenance area is wellventilated.

- The continuous ventilation status should be kept during the operation process.

Check whether there is fire source or potential fire source in the maintenance area.

-
- The naked flame is prohibited in the maintenance area; and the "no smoking" warning board should be hanged.
- Check whether the appliance mark is in good condition.
- Replace the vague or damaged warning mark.

Welding

If you should cut or weld the refrigerant system pipes in the process of maintaining, please follow the steps as below:

- a. Shut down the unit and cut power supply;
- b. Eliminate the refrigerant;
- c. Vacuuming;
- d. Clean it with N₂ gas;
- e. Cutting or welding;
- f. Carry back to the service spot for welding;

The refrigerant should be recycled into the specialized storage tank.

Make sure that there isn't any naked flame near the outlet of the vacuum pump and it's wellventilated.

Filling the refrigerant

Use the refrigerant filling appliances specialized for R290. Make sure that different kinds of refrigerant won't contaminate with each other.

The refrigerant tank should be kept upright at the time of filling refrigerant.

Stick the label on the system after filling is finished (or haven't finished)

Don't overfilling.

After filling is finished, please do the leakage detection before test running; another time of leak detection should be done when it's removed.

Safety instructions for transportation and storage

Please use the flammable gas detector to check before unload and open the container.

No fire source and smoking.

According to the local rules and laws.

2. Preparations of installation

2.1 Transport

- In order to avoid scratch or deformation of the unit surface, please use guard boards to contacting surface.
- No contact of fingers and other things with the vanes.
- Do not incline the unit more than 25° to move. While installing the unit, keep the unit vertical.

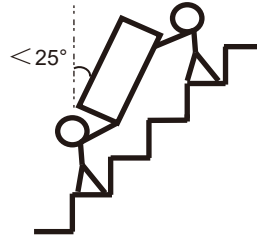

- Because the unit is very heavy, it requires two or more people to carry the unit, and otherwise, it might cause injury and damage of the unit.

2.2 Packing list

Item	Quantity
Heat pump water heater	1
Installation & user manual	1
PTR valve	1
Condensation tube	1
Condensation tube joint	1

2.3 Installation site requirements

- Enough space for the unit installation and maintenance should be preserved.
- The surrounding of air inlet and outlet should be free from obstacles and strong wind.
- The base surface should be flat, surface should be inclined no more than 2° and able to bear the weight of the unit and suitable for installing the unit without increasing noise or vibration.
- The operation noise and air flow expelled shall not affect neighbors.
- No flammable gas is leaked nearby.
- It is convenient for piping and wiring.
- If it is installed in indoor space, it might cause indoor temperature decreased or noise. Please take preventive measures for this.
- If the unit has to be installed on a metal part of the building, make sure that the reliable electric insulation which should meet the relevant local electric standard.



CAUTION

- The ambient air temperature must also be considered when installing this unit, in heat pump mode the ambient air temperature must be above -10°C and below 40°C. If the ambient air temperature falls outside these upper and lower limits, the electrical elements will be activated to meet the hot water demand and the heat pump does not operate.
- The unit should be located in an area not subject to freezing temperatures. The unit located in unconditioned space (garages, basements, etc.) may require the water piping condensate piping, and drain piping to be insulated to shelter against freezing.
- When installing the unit in the following places, it may lead to the malfunction of the unit: (If it is inevitable, please consult with the unit supplier.)
 - The place contains mineral oils, for example, lubricant of cutting machines.

- Seaside where the air contains salt.
- Hot spring area where there are some corrosive gases like sulfide gas.
- Factories where the high voltage power fluctuates seriously.
- Inside a car or cabin.
- The place with direct sunlight and other heat supplies. If it is not avoid, please install a covering or take other measurement.
- Place where is contained by oil permeates like kitchen.
- Strong electromagnetic wave surrounding.
- The place filling with danger or flammable gases or materials.
- The place filling with acid or alkali gases.



WARNING

- The unit must be securely installed; otherwise some noise and shaking may be produced.
- Confirm that there is no any obstacle around the unit.
- If there is strong wind like seashore, please fix the unit in the place where is protected from the wind.

2.4 Maintenance space requirements

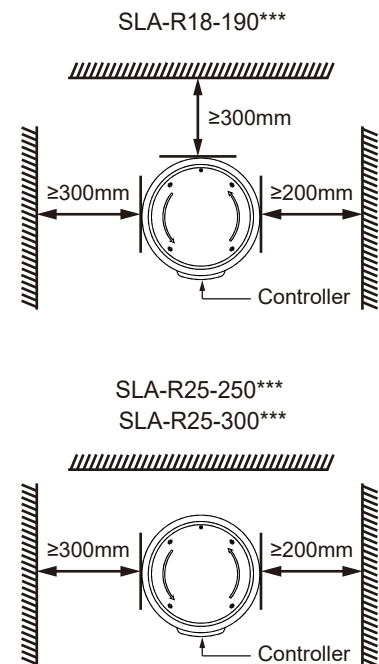
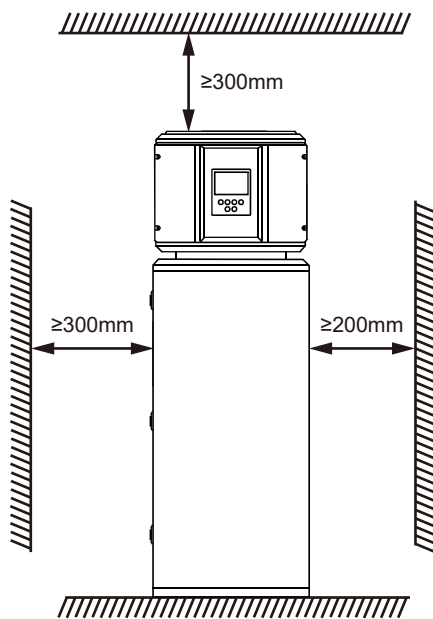

Note:

Top clearance is primarily a maintenance rather than operational requirement. If top clearance is reduced future maintenance (if required) cost may increase due to need to move and then return unit to original position.

2.5 DO NOT INSTALL THE UNIT IN ENCLOSED SPACE.

2.6 Unit dimension

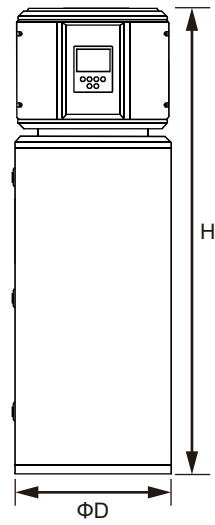

Model	D	H
SLA-R18-190***	510mm	2175mm
SLA-R25-250***	640mm	1800mm
SLA-R25-300***	640mm	2010mm

3. Installations

It is NECESSARY for installation to conform with AS/NZS 3500.4.



WARNING

Water quality requirements (chloride and pH):

- In areas of water supplies with high chloride levels, water can corrode certain parts, causing them to fail.
- Not suitable for heat pump units and storage tank units if the chloride content exceeds 200 mg/l.
- pH is a measure of whether water is alkaline or acidic.
- Heat pump units and hot water tank units with a pH value less than 6.0 are not guaranteed.
- The water supply to rainwater storage tanks within urban agglomerations can be corrosive due to the dissolution of atmospheric pollutants.

If the water heater is supplied with poor quality water, then it is necessary to install water softeners.

3.1 Water system piping diagram

SLA-R18-190***

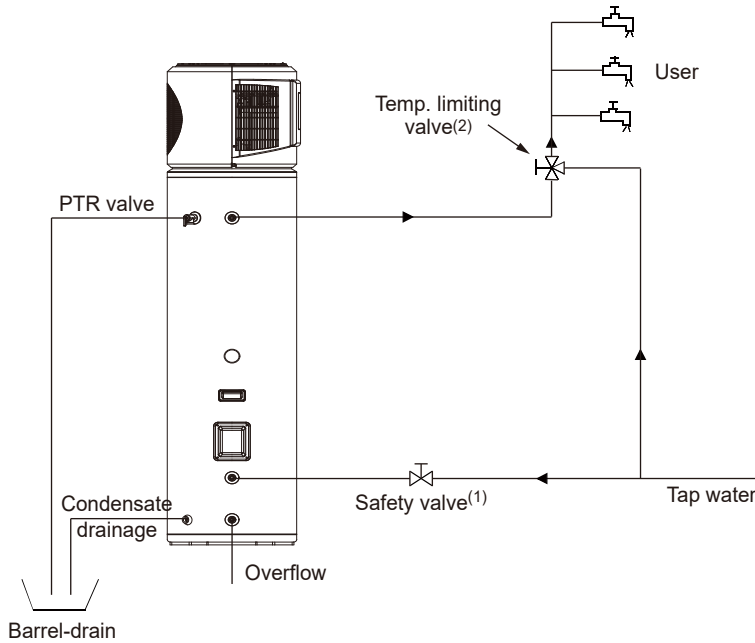

Notes:

- (1) The drainage pipe of the safety valve as accessories should be connect with the atmosphere.
- (2) The temperature limiting valve is required on the hot water usage terminal.

SLA-R25-250***, SLA-R25-300***

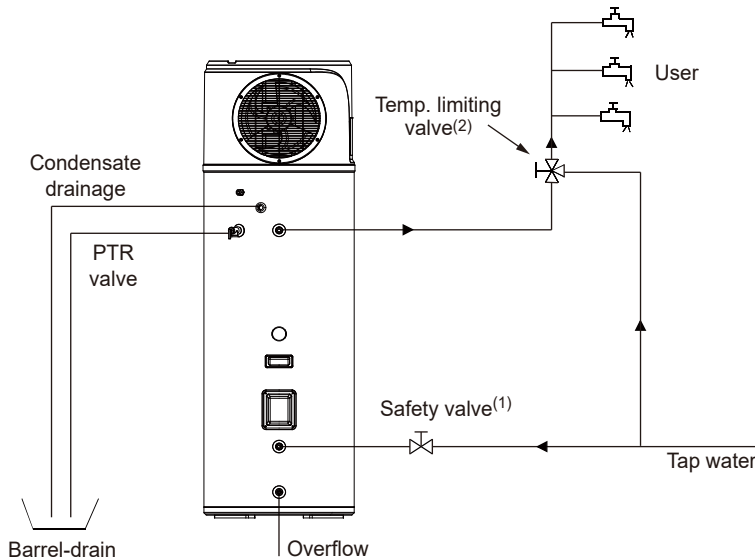

Notes:

- (1) The drainage pipe of the safety valve as accessories should be connect with the atmosphere.
- (2) The temperature limiting valve is required on the hot water usage terminal.



CAUTION

- Water piping system as the above figure. When install the unit at a place where outside temperature below freezing point, the insulation must be provided for all hydraulic components.
- The handle of PTR valve should be pulled out once per half a year to confirm that there is no jam of the valve. At the same time, please take care of hot water from the valve and burning.
- The outlet drain pipe should be insulated well in order to prevent water which is kept inside the pipe from freezing in cold conditions. At the same time, the outlet drain pipe should be insulated well because the outlet water temperature is very high.

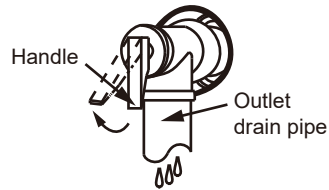

WARNING

It will cause explosion and injury, if do not comply with the following instruction:

- Do not dismantle the PTR valve.
- Do not block off the outlet drain pipe.

The specifications of water inlet and outlet pipes as following:

- SLA-R18-190*** Internal thread (G3/4),
- SLA-R25-250***, SLA-R25-300***: Internal thread (G3/4).
- Pipes must be heat-insulated well.

- After water system piping work, turn on the cold water inlet valve and hot water outlet valve and start effusing the tank. When water flow smoothly out from tap of water outlet, it means the tank is full. Please turn off all valves and check pipeline to make sure there is without any leakage.
- If the inlet water pressure is less than 0.15MPa, a pump should be installed at the water inlet pipe.
- For the safety usage of water tank at the condition of water supply pressure higher than 0.80MPa, a reducing valve should be installed at the water inlet pipe.
- Condensate may be leaked from the unit if condensate drainage pipe is blocked or it operates in high humidity environment, a drainage pan is recommended as shown as the following figure:

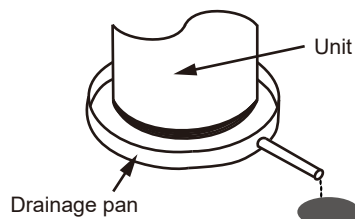

3.3 Condensate water drainage

To smoothly drain the condensate water, please install the unit at a horizontal floor. At the same time, please ensure the drainage joint is at the lowest level. Recommending the inclination angle of the unit to the ground should be no more than 2°.

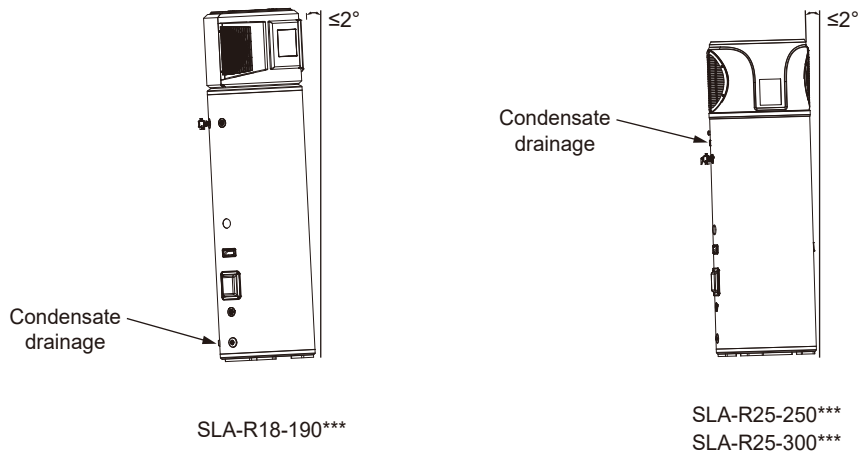

3.4 Electric connection



CAUTION

- The power supply should be an independent circuit with rated voltage.
- Power supply circuit should be earthed effectively. The wiring must be performed by professional technicians in accordance with nation wiring regulations and the unit circuit diagram.
- An all-pole disconnection device which has at least 3mm separation distance in all poles and a residual current device (RCD) shall be incorporated in the fixed wiring according to the national rules.
- Set the electric leakage protector according to the relevant electric technical standards of the state.
- The power supply cord and signal cord shall be laid out neatly and properly without mutual interference or contacting the connection pipes.
- After wires connection, check it again and make sure the correctness before power on.

3.4.1 Electric wiring diagram

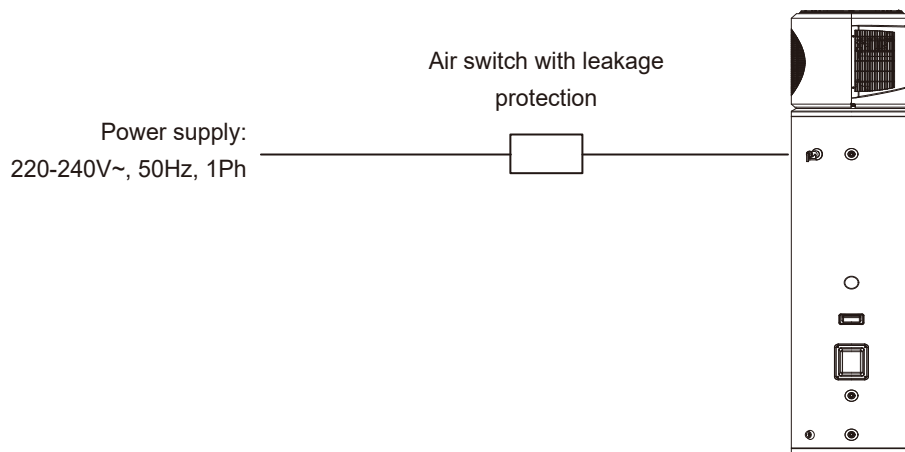



WARNING

- In order to ensure safety, the air switch with leakage protection must be installed at the external power supply box of the unit as shown above.
- This product can be used only when the grounding is confirmed to be reliable.

3.4.2 Specifications of power supply

	SLA-R18-190***	SLA-R25-250*** SLA-R25-300***
Power supply	220-240V~, 1Ph, 50Hz	
Min. diameter of power supply cord	2.5mm ²	2.5mm ²
Earth cord	2.5mm ²	2.5mm ²
Creepage Breaker	30mA, ≤0.1Sec	30mA, ≤0.1Sec

- Please choose the power supply cord according to the above table, and it should comply with local electric standard.
- The power supply cord model, recommended power supply cord is H05RN-F.



WARNING

The unit must be installed with a creepage breaker near the power supply and must be effectively earthed.

3.4.3 Wiring diagram

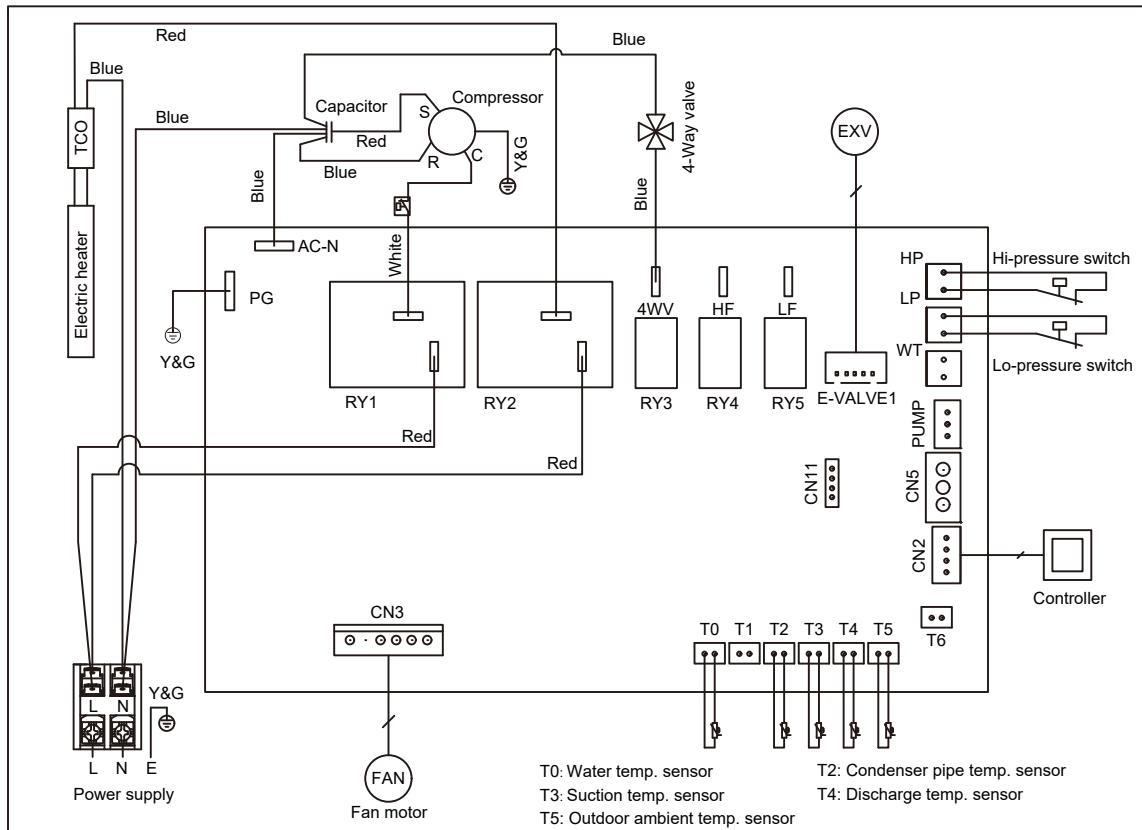

3.5 Installation checking

3.5.1 Location checking

- The flooring beneath the water heater must be able to support the weight of the unit when filled with water.
- Located indoors (such as a basement or garage) and in a vertical position. Sheltered from the freezing temperatures.
- Provisions made to shelter the area from water damage. Metal drain pan installed and piped to an adequate drain.
- Sufficient space to service the water heater.
- Sufficient air for the heat pump to function, the water heater must be located in a space which must have unrestricted air flow.



NOTES

For optimal efficiency and service ability, the following clearances should be maintained: 200/600mm on the air inlet side , 800mm on the air outlet side in the back.

-
- The unit cannot be placed into any type of closet or small enclosure.
 - The site location must be free from any corrosive elements in the atmosphere such as sulfur, fluorine and chlorine. These elements are found in aerosol sprays, detergents, bleaches, cleaning solvents, air fresheners, paint and varnish removes, refrigerants and many other commercial and household products. In addition excessive dust and lint may affect the operation of the unit and require more frequent cleaning.
 - The ambient air temperature must be above -10°C and below 40°C. If the ambient air temperature falls outside these upper and lower limits the electrical elements will be activated to meet the hot water demand.

3.5.2 Checking of the water system piping

- PTR valve (Temperature and pressure relief valve) properly installed with a discharge pipe run to an adequate drain and sheltered from freezing.
- All piping properly installed and free of leaks.
- Unit completely filled with water.
- Water temperature limit valve or mixer tap (Recommended) installed per manufacturer's instructions.

3.5.3 Checking of condensate drain pipe

- Must be located with access to an adequate drain or condensate pump.
- Condensate drain lines installed and piped to an adequate drain or condensate pump.

3.5.4 Checking of the electrical connections

- The water heater requires 220-240VAC for proper operation.
- Wiring size and connections comply with all local applicable codes and the requirements of this manual.
- Water heater and electrical supply are properly grounded.
- Proper overload fuse or circuit breaker protection installed.

3.5.5 Post installation review

- Understand how to use the controller to set the various parameters and functions.
- Understand the importance of routine inspection/maintenance of the condensate drain pan and lines. This is to help prevent any possible drain line blockage resulting into the condensate drain pan overflowing.
- IMPORTANT:** Water coming from the plastic shroud is an indicator that both condensation drain lines may be blocked. Immediate action is required.

4. Trial-running

4.1 Water affusion before operation

If the unit is used for the first time or used again after emptying the water tank, please make sure that the tank is full of water before turning on the power.

Method: please refer to the figure.

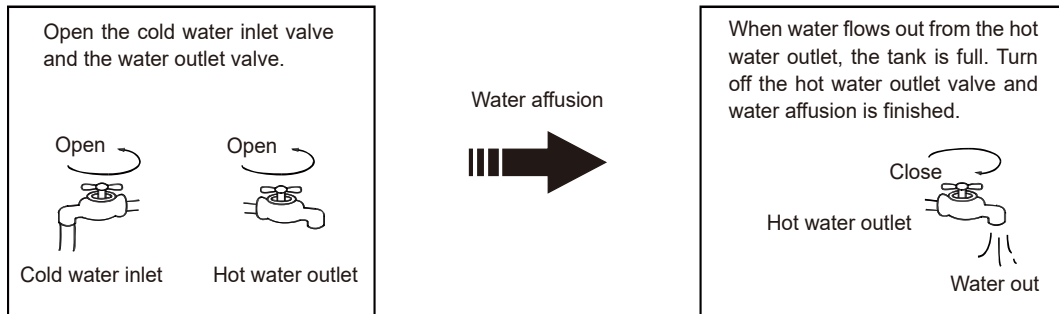

CAUTION

- Operation without water in water tank may result in the damage of the boost E-heater (electrical heater). Due to such damage, manufacturer will not be responsible for any damages caused by this issue.
- After powered on, the display lights up. Users can operate the unit through the buttons under the display.

4.2 Water emptying from water tank

If the unit needs cleaning, moving, etc, the water tank should be emptied.

Method: please refer to the figure.

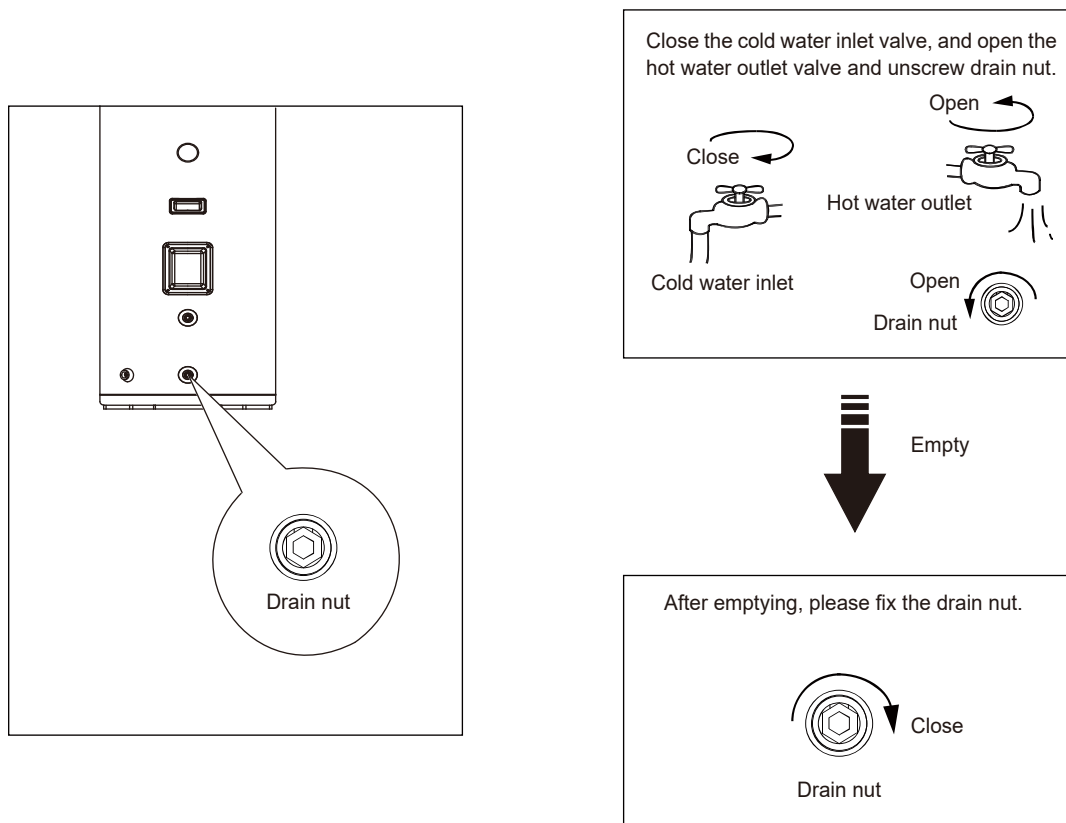

4.3 Checking list before commissioning

- Correct installation of the system.
- Correct connection of the water and wiring.
- Condensate draining smoothly well insulation work for all hydraulic part.
- Correct power supply.
- No air in the water pipeline and all valves opened.
- Effective electric leakage protector installation.
- Sufficient inlet water pressure (Between 0.15MPa and 0.80MPa).

5. Operation

5.1 Controller panel explanation

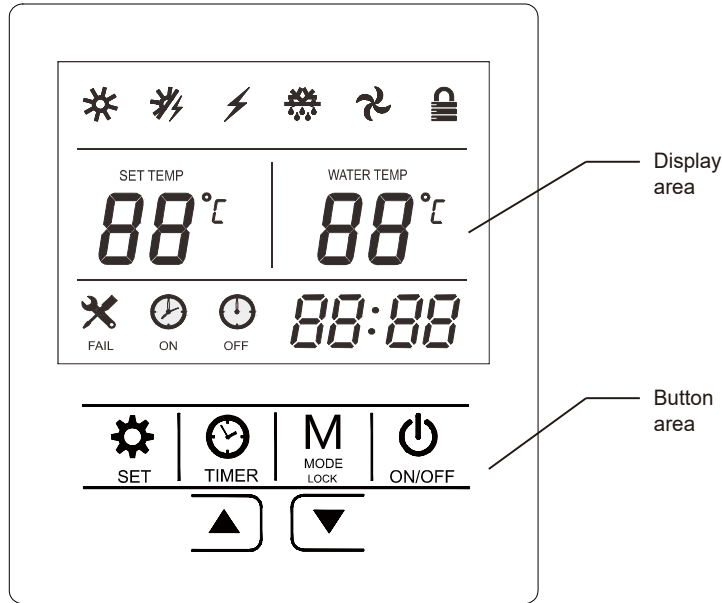







5.2 Explanation of icons

Icons	Explanations	Icons	Explanations
	Heat pump mode		Malfunction icon.
	Fast heating mode (heat pump + boost E-heater)		Timer on/Timer off icon.
	Electric heater mode		Clock icon.
	Defrost icon. Under the defrost mode, it will be lightened. Under the protection of the anti-freezing fuction, it will be flashed.		The setting value of water temperature
	Fan icon. It will be lightened, once the fan runs.		The current value of water temperature
	Lock icon.		

- After the unit is powered ON, the display screen will display all the icons for 3 seconds, and then it will display the regular interface automatically.

5.3 Explanation of buttons

Icons	Name	Icons	Name
 SET	Setting button	 ON/OFF	ON/OFF button
 TIMER	Timer button		Increase/up button
 MODE LOCK	Mode - lock button		Decrease/down button

5.3.1 On/Off button



In the unit standby state, hold down this button for 2 seconds to switch on the unit. When the unit is running, hold it down for 2 seconds to shutdown the unit.

5.3.2 Mode button



During the unit running, press mode button, and the unit will change the operating mode as following figure:

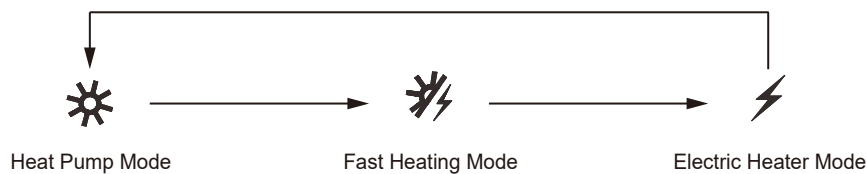

Only under the heat pump mode, boost electric heater will not be triggered.

During the unit running, after keep pressing the button for 3 seconds, all the buttons will be locked and the icon  will be displayed. Press it for 3 seconds again, the lock function will be canceled.

5.3.3 Set button



Press the set button, the running parameters of the unit will be display. Press the ▲ and ▼ buttons to change the parameter items.

Item	Explanation	Range of the parameter
A	Temperature of the lower water layer in tank	-20°C - 99°C
B	Temperature of the upper water layer in tank	-20°C - 99°C
C	Refrigerant temperature inside the coil	-20°C - 99°C
D	Suction temperature of the compressor	-20°C - 99°C
E	Outdoor ambient temperature	-20°C - 99°C
F	Running steps of the EXV	100 - 470
H	Discharge temperature of the compressor	0°C - 125°C



Notes

- If unit is set to run under Fast heating mode or Electric heater mode, the unit will switch to heat pump mode with factory setting temperature (set point temperature for heat pump control) from other mode automatically after 24 hours.
- When the setting temperature is changed under the heat pump mode, the setting temperature will be restored to factory setting value after 24 hours.

SLA-R18-190D/N4A4	Set point Temp. for heat pump control: 55°C, dead band: 5°C.
SLA-R25-250D/N4D4	
SLA-R25-300D/N4D4	Set point Temp. for heat pump control: 50°C, dead band: 5°C.
SLA-R18-190D/N4A4C/70-2	Set point Temp. for heat pump control: 70°C, dead band: 2°C.
SLA-R25-250D/N4D4C/70-2	
SLA-R25-300D/N4D4C/70-2	
SLA-R18-190D/N4A4C/70-5	Set point Temp. for heat pump control: 70°C, dead band: 5°C.
SLA-R25-250D/N4D4C/70-5	
SLA-R25-300D/N4D4C/70-5	

- To disable the automatic reset function,
 - Press and hold the "SET" button for 5 seconds, then use the "▲" and "▼" keys to scroll through settings.
 - Go to setting 35, press "SET" again to enter the setting edit state.
 - Use the "▲" and "▼" keys to modify the parameter value to "0". Here "0" indicates disable, and "1" indicates enable.



Caution: Disabling the automatic reset function affects energy efficiency. It prevents the system from going back to Heat Pump Mode (Eco mode) with 50 degree C set temperature. The original default settings and system performance have been optimized according to the standard AS/NZS 4234:2021. This default setting has been registered and approved in the *Greenhouse and Energy Minimum Standards (GEMS)*. Therefore, it is strongly advised not to disable the automatic reset function.

5.3.4 Timer button



Press the timer button to set the clock and timer on/off.

Clock setting -

Step 1: Press the Timer button to set the clock. So the hours of clock begins to flash.

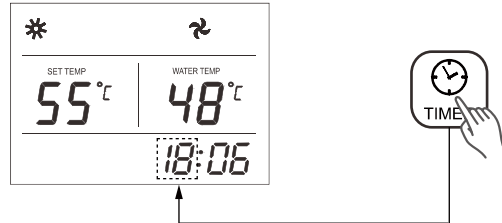

Step 2: Press Increase or Decrease button to set correct hours of clock. After setting the hours, press the Timer button again to begin to set the minutes of clock. So the minutes of clock begins to flash.

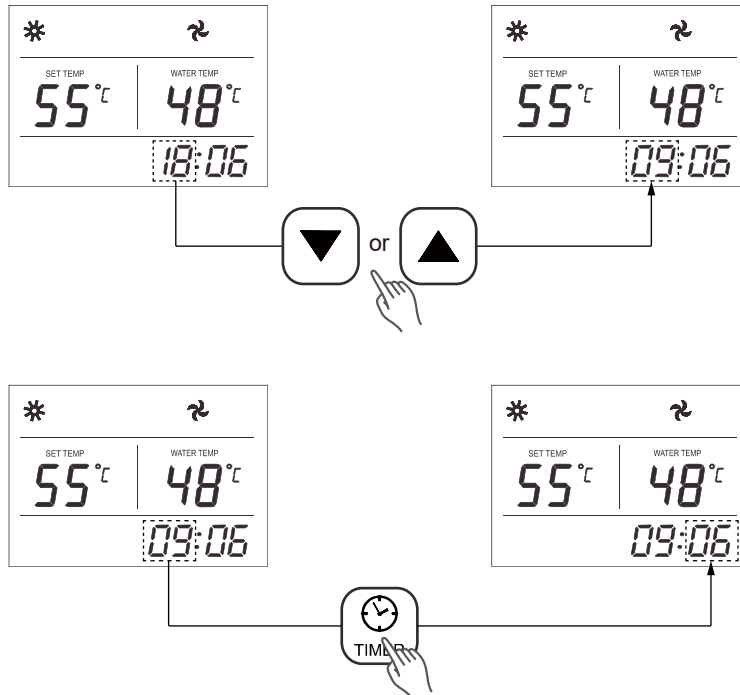

Step 3: Press Increase or Decrease button to set correct minutes of clock. Finally, press the timer button again to confirm and exit the clock setting.

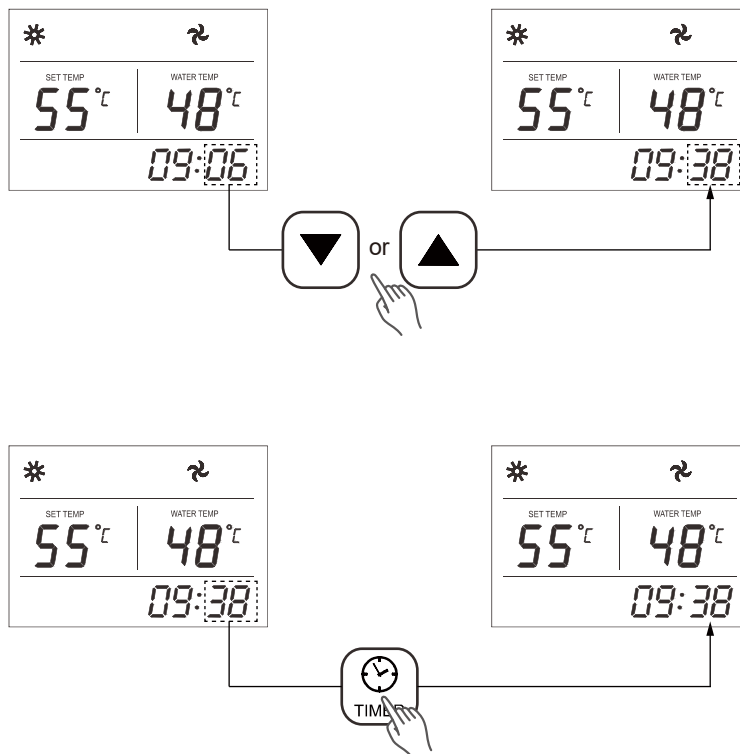

Timer setting -

Step 1: Hold down the Timer button for 5 seconds till the icon of timer on is flashed and the icon of timer off displayed. So timer on can be set now. At the same time, hours of timer on flashes.

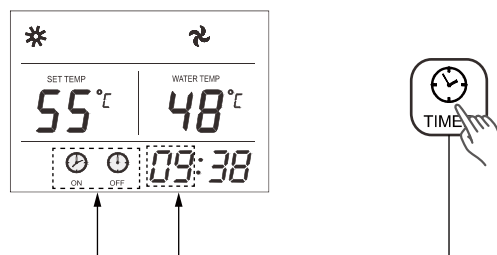

Step 2: Press Increase or Decrease button to set required hours of timer on. After setting the hours, press the Timer button again to begin to set the minutes of timer on. So the minutes begins to flash.

Notes: During the setting of timer on, the icon of timer on will keep flashing.

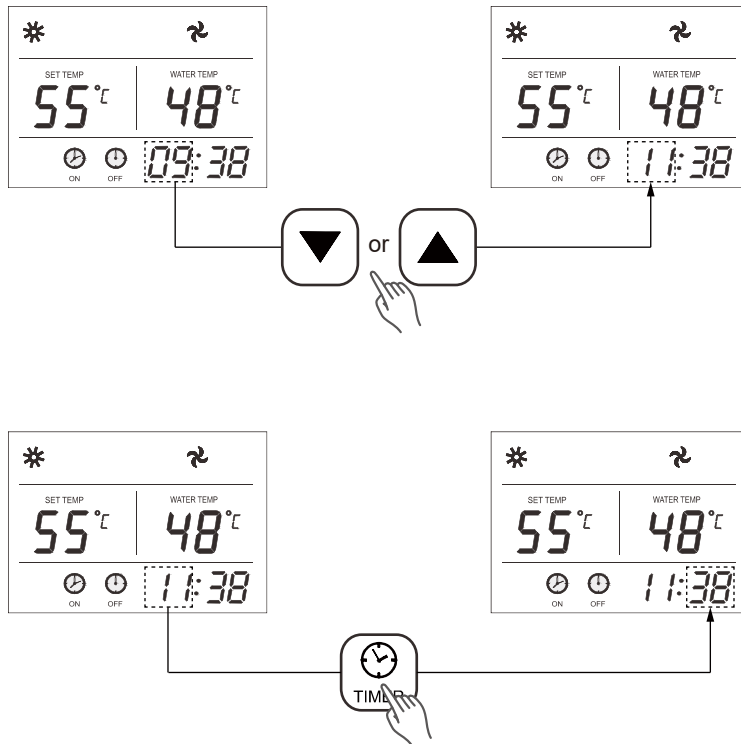

Step 3: Press Increase or Decrease button to set required minutes of timer on. Finally, press the Timer button again to confirm the timer on setting and begin to set timer off. At this time, the icon of timer off and hours of timer off will be flashing.

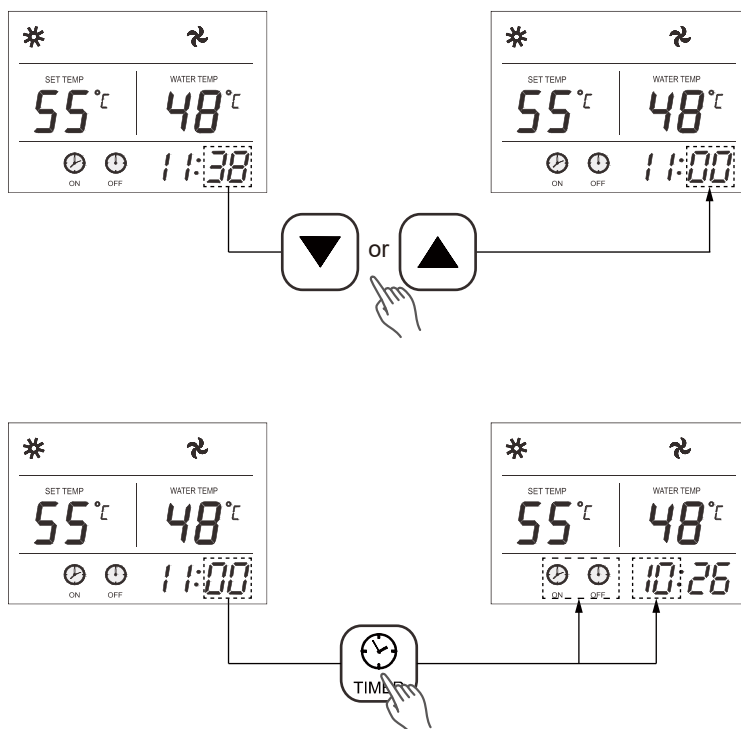

Step 4: Press Increase or Decrease button to set required hours of timer off. After setting the hours, press the Timer button again to begin to set the minutes of timer off. So the minutes begins to flash.

Notes: During the setting of timer off, the icon of timer off will keep flashing.

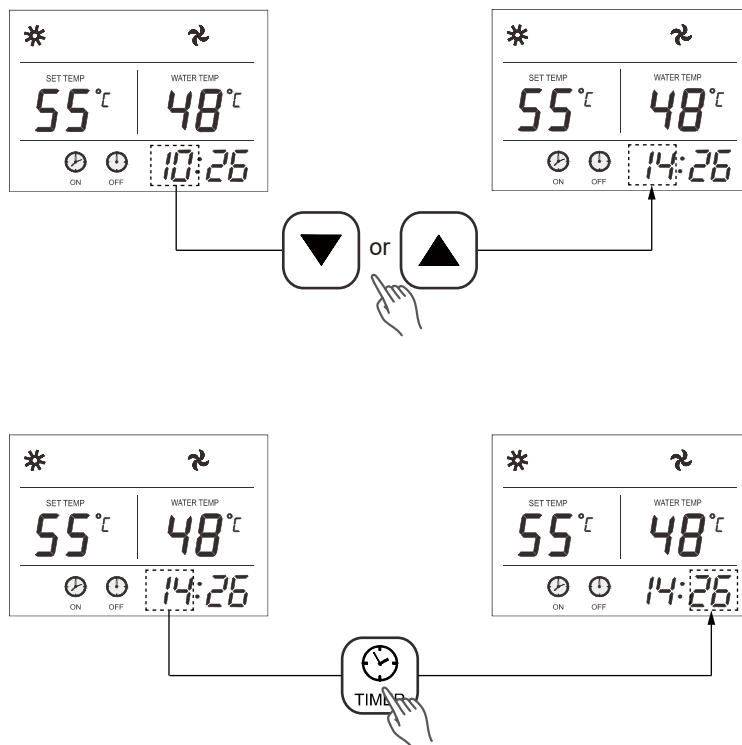

Step 5: Press Increase or Decrease button to set required minutes of timer off. Finally, press the Timer button again to confirm the timer off setting and exit the timer setting.

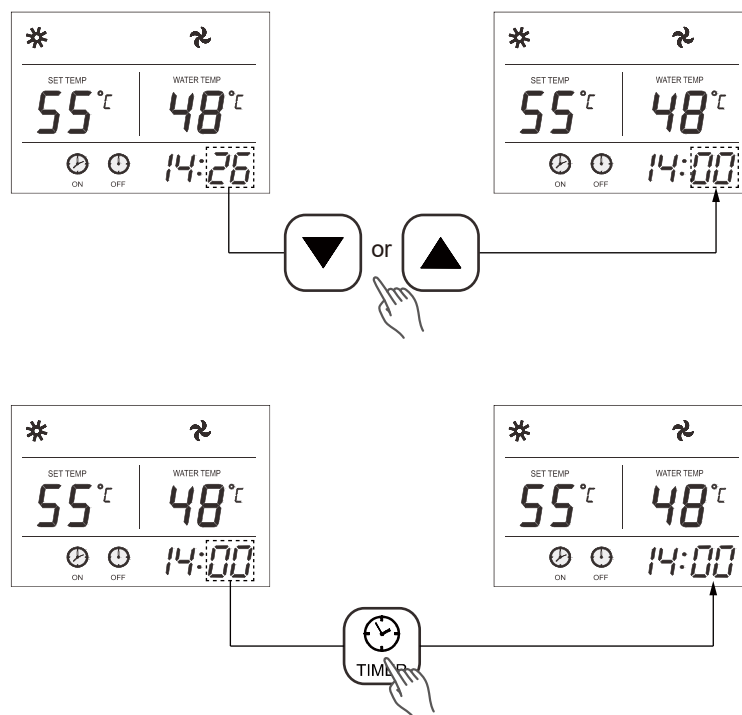

Notes: Once timer on/off is successfully set, the icons of timer on and off will be displayed.

Cancelling timer setting -

In the process of timer on/off setting, press the Set button, and all the timer setting will be canceled.

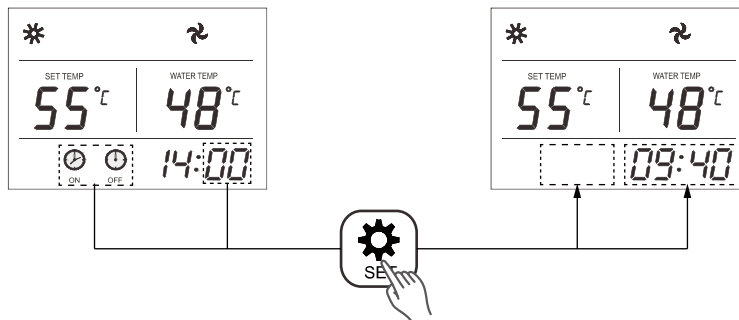

5.3.5 Increase/up button and Decrease/down button



These two buttons is used when the temperature setting, the clock setting and parameters query.

Under the running state of the unit, the water setting temperature can be raised by pressing the increase/up button, while the water setting temperature can be lowered by pressing the Decrease/down button.

5.3.6 Disinfect function

SLA-R18-190D/N4A4	Weekly legionella boost can occur between 1 AM - 7 AM. The 90% tank volume is heated to 61°C set point with 1K deadband.
SLA-R25-250D/N4D4	
SLA-R25-300D/N4D4	
SLA-R18-190D/N4A4C/70-2	The 45% tank volume is heated to at least 60°C daily.
SLA-R25-250D/N4D4C/70-2	
SLA-R25-300D/N4D4C/70-2	
SLA-R18-190D/N4A4C/70-5	
SLA-R25-250D/N4D4C/70-5	
SLA-R25-300D/N4D4C/70-5	

6. Troubleshooting

6.1 Non-error tips

Q: Why compressor cannot start immediately after setting?

A: Unit will wait for 3 minutes to balance the pressure of the refrigerant system before starting compressor again. It is a self protection logic of the unit.

Q: Why sometimes the temperature shown on the display decreased while unit is running?

A: When the temperature of layer water inside the tank is much higher than the bottom part, upper hot water will be mixed by the bottom cold water which is continually flow from the inlet tap water so that will decrease the water temperature of upper part .

Q: Why sometimes the temperature shown on the display decreased but the unit still keep off?

A: To avoid the unit turning on/off frequently, the unit will activate heat pump only when the water temperature in the bottom of the tank is lower than the setting temperature.

Q: Why sometimes the unit shows 'PA' on the display?

A: The heat pump available running ambient temperature is from -10°C to 40°C. If the ambient temperature is out of this range, the unit will show the PA to let user notice it.

Q: Why sometimes there is some water flowed from drainage pipe of PTR valve? (When the unit with PTR valve)

A: Because the water tank is pressure-bearable one, when water is heated inside the tank, water will expand, so the pressure inside the tank will increase. If the pressure goes up more than 1.0MPa, PTR valve will activate to relief the pressure and hot water drop will be discharged correspondingly. If water drop is continually discharged from PTR valve drainage pipe, it is abnormal, please contact qualified staff to repair.

6.2 Something about self-protection of unit

■ When the self-protection happens, the unit will be stopped and start self-check, and restart when the protection resolved.

■ In the following circumstance, self-protection may happen:

Air inlet or outlet is blocked;

The coil is covered with too much dust;

Incorrect power supply (Exceeding the range of 220-240V).

6.3 Error phenomenon shooting

Error phenomenon	Possible reason	Solution
Cold water tapped out and display screen extinguished	Bad connection between power supply plug and socket.	Plug in again.
	Setting water temperature is too low.	Set the water temperature higher.
	Temperature sensor or PCB is broken.	Contact service center.
No hot water tapped out	Public water supply is ceased.	Wait for water supply to recover.
	Cold water inlet pressure is too low. (less than 0.15MPa)	Wait for inlet water pressure increase.
	Cold water inlet valve is closed.	Open the water inlet valve.
Water leakage	Hydraulic pipeline joints are not sealed well.	Check and reseal all joints.

6.4 Error code shooting table

Code	Description	Corrective action
P01	Lower water temperature sensor error	Check connection to sensor.
		Replace sensor if broken.
		Replace PCB if broken.
P03	Coil temperature sensor error	Check connection to sensor.
		Replace sensor if broken.
		Replace PCB if broken.
P04	Suction temperature sensor error	Check connection to sensor.
		Replace sensor if broken.
		Replace PCB if broken.
P05	Outdoor ambient temperature sensor error	Check connection to sensor.
		Replace sensor if broken.
		Replace PCB if broken.
P06	Anti-freezing protection	This protection is normal. The unit which is under standby state will trigger this protection when the water tank sensor detects the water temperature is lower than 5°C.
P07	Discharge temperature sensor error	Check connection to sensor.
		Replace sensor if broken.
		Replace PCB if broken.
E01	High pressure protection	Check connection to switch.
		Replace switch if broken.
		Check refrigerant system isn't blocked.
		Check the refrigerant volume isn't too high.
E02	Low pressure protection	Replace PCB if broken.
		Check the low pressure switch connection is not well.
		Check if pressure switch is broken.
		Check if refrigerant system is block.
		Check for leakage in refrigerant system to repair.
E03	Fan motor failure	Check refrigerant volume isn't too low.
		Replace PCB if broken.
E04	Over-high protection of discharge temperature	Replace motor if broken.
		Replace PCB if broken.
		Check if temperature sensor connection is not well.
		Check if discharge temperature sensor is broken.
		Check if the refrigerant system is block.
PA	It is normal and no need repair. The heat pump available running ambient temperature is from -10°C to 40°C. If the ambient temperature is out of this range, the unit will show the PA to let user notice it. During this period, the boost electrical heater can be used.	Check if the refrigerant is too much.
		Replace PCB if broken.

Code	Description	Corrective action
E08	Communication error	Check connection between PCB and controller if its broken.
		Replace the controller is broken.
		Replace the PCB if its block.

NOTE

- The diagnostic codes listed above are the most common. If a diagnostic code not listed above is displayed, please contact residential technical assistance.
 - If any of E01/E02/E04 continuously appear 3 times within 30 minutes, the unit will consider it as heat pump system error, and the unit will stop running. The unit will not run until the power supply is reset.
-

7. Maintenance

7.1 Maintenance

- Check the connection between power supply plug, socket and ground wiring regularly.
- In some cold area (below 0°C), if the unit will be stopped for a long time, all the water should be released in case of freezing of inner tank and damage of boost electrical heater.
- It is recommended to clean the inner tank and boost E-heater every half year to keep an efficient performance.
- Check the anode rod every half year and change it, if it has been used out. For more details, please contact the supplier or the after-sale service.
- It is recommended to set a lower temperature to decrease the heat release, prevent scale and save energy if the outlet water volume is sufficient.
- Before shutting the system off for a long time, please:
Shut off the power supply;
Release all the water in the water tank and the pipeline. Close all the valves;
Check the inner components regularly.

7.2 How to change the anode rod

- Turn off the power supply, and turn off the water inlet valve.
- Open hot water tap, and decrease the pressure of the inner tank.
- Open the drainage valve, and drain out the water, until there are no water flow out.
- Remove the cover / panel of top part, and take out the anode rod.
- Replace it with a new one, and make sure effective sealed.
- Open cold water inlet tap until water flows out from outlet tap then close water outlet tap.
- Power on and restart the unit.

7.3 Recommended regular maintenance table

Item	Checking content	Check frequency	Action
1	Anode rod	Every 6 months	Replace it if it has been used out.
2	Inner tank	Every 6 months	Clean the tank.
3	Boost E-heater	Every 6 months	Clean E-heater.
4	PTR valve	Every 12 months	Operate the handle of the PTR valve to ensure that water can be flowed out.
			If water does not flow freely when operating the handle, replace PTR valve with a new one.

8. Specifications

Model	SLA-R18-190***	SLA-R25-250***	SLA-R25-300***
Power supply	220-240V~, 50Hz, 1Ph		
Running ambient air Temp.	-10°C - 40°C	-10°C - 40°C	-10°C - 40°C
Rated water supply pressure	800kPa	800kPa	800kPa
PTR valve setting	850kPa	850kPa	850kPa
Rated power input (Heat pump)	350W	480W	480W
Heating capacity (Heat pump)	1750W	2500W	2500W
Max. input power / current	2680W / 12.0A	2870W / 13.0A	2870W / 13.0A
Outlet water Temp.	35°C - 70°C	35°C - 70°C	35°C - 70°C
Water connection size	G3/4"	G3/4"	G3/4"
Operation pressure (High / Low)	2.8MPa / 0.6MPa	2.8MPa / 0.6MPa	2.8MPa / 0.6MPa
IP data	IPX4	IPX4	IPX4

Rated input power (heat pump only) and heating capacity are based on the following condition:

Tank water temperature from 14°C to 55°C

Air at 19°C Dry Bulb / 15°C Wet Bulb

Document version history

Version	Amendments	Effective Date
1.0	First release	July 2024
1.1	Updated automatic reset function information and paragraph format	August 2024