

Smart Lifestyle Australia

Battery

User Manual

Installation and Operation

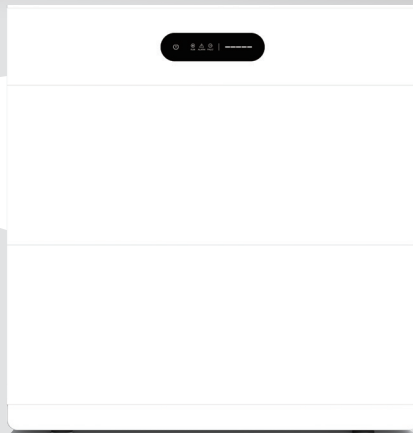

EXCLUSION OF LIABILITY

All names, trademarks, product names or other designations used in this manual may be legally protected even if not indicated as such (e.g. as a trademark). **Smart Lifestyle Australia Pty Ltd.** assumes no liability or warranty for their free usage. The illustrations and texts have been compiled with great care. However, the possibility of errors cannot be ruled out. The compilation is made without any guarantee.

GENERAL NOTE ON GENDER EQUALITY

Smart Lifestyle Australia Pty Ltd. is aware of the importance of language with regard to the equality of women and men and always makes an effort to reflect this in the documentation. Nevertheless, for the sake of readability we are unable to use non-gender-specific terms throughout and use the masculine form instead.

© 2023 Smart Lifestyle Australia Pty Ltd.

All rights reserved by Smart Lifestyle Australia Pty Ltd. including those of reproduction by photocopy and storage in electronic media. Commercial use or distribution of the texts, displayed models, diagrams and photographs appearing in this product is not permitted. This manual may not be reproduced, stored, transmitted or translated in any form or by means of any medium, in whole or in part, without prior written permission.

CONTENTS

1 Introduction	01
1.1 Product introduction.....	01
1.2 Target Group.....	03
1.3 Information about safety.....	03
1.4 Battery safety specification.....	08
1.5 General precautions.....	08
1.6 Handle heavy loads safely.....	09
1.7 List of installation accessories.....	10
1.8 Limitation of liabilities.....	11
2 Installation	12
2.1 Equipment Installation.....	12
2.2 Installation site and environment.....	13
2.2 Installation.....	16
2.3 Communication connection.....	21
2.4 Cable connection.....	22
2.5 Install grounding protection wire.....	24
3 System operation	26
3.1 Start.....	26
3.2 Turn off.....	26
3.3 Emergency procedure.....	26
3.4 Product protection.....	28
4 Battery status description	29
4.1 Battery System LED Display Description.....	29
5. Battery storage and recharging	31
5.1 Battery storage requirements.....	31
5.2 Storage expiration.....	32
5.3 Inspection before battery recharging.....	33
5.4 Recharge Operation Steps.....	33
6. Battery port definition and parameters	34
6.1 Port definition.....	34
6.2 Internal wiring of the system.....	35
6.3 Battery parameters.....	37
7. Routine maintenance	38
7.1 Maintenance plan.....	38
7.2 Cautions.....	39
8. Fault codes and solutions	39
9. Quality commitments	43
10. Remote access	44
10.1 Operation instructions.....	44
10.2 Safety instructions.....	44
Appendix A: PV Connection Steps	45
Appendix B: Two Poles Isolation	46

1 Introduction

1.1 Product introduction

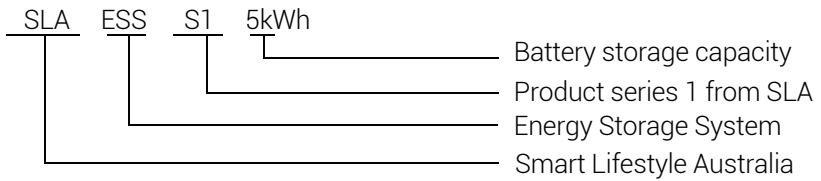

SLA-ESS-S1-5kWh can be used in conjunction with inverters and can store and release electrical energy according to the requirements of the inverters.

Configuration	
SLA-ESS-S1-5kWh	Base+BMS+1*Module
SLA-ESS-S1-10kWh	Base+BMS+2* Module
SLA-ESS-S1-15kWh	Base+BMS+3* Module
SLA-ESS-S1-20kWh	2*(Base+BMS+2*Module)
SLA-ESS-S1-30kWh	2*(Base+BMS+3* Module)

Storage capacity description

The capacity of battery packs can be increased by connecting them in series or parallel, as shown in the following.

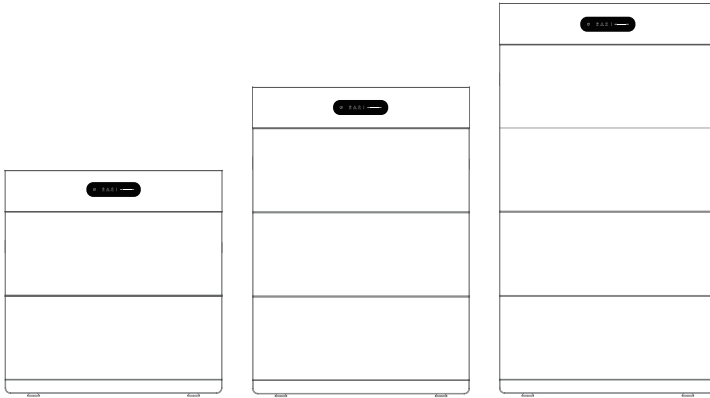

2~4 battery packs in series

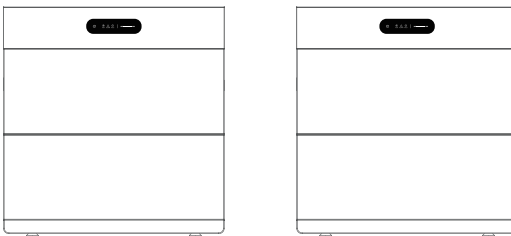

Two sets in parallel/Two packs in series of each set

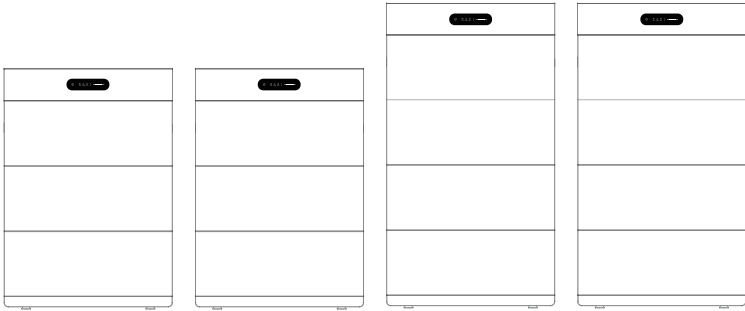

Two sets in parallel / three or four packs in series of each set

1.2 Target Group

This manual is for qualified electricians. The tasks described in this manual only can be performed by qualified electricians.

1.3 Information about safety











Manual preservation

This manual contains important information about equipment operations. Please read it carefully before any operation and carry out the operations strictly according to the instructions in the manual. Otherwise, it will cause equipment damage, personnel and property damage or loss. Be sure to keep this manual for maintenance and repair.

Operator requirements

The operator should have professional qualifications or be trained. The operator should be familiar with the composition and operating principle of the whole storage system including equipment. The operator should be familiar with the product manual. During maintenance, the maintenance personnel should not operate any equipment until all equipment is turned off and the power is switched off.

Symbols on the Type Label

Symbol	Explanation
	CE mark. The inverter complies with the requirements of the applicable CE
	TUV mark
	The battery should be recycled environmentally and safely in proper facilities.
	Danger to life due to high voltages in the inverter!
	Danger Risk of electric shock!
	Observe enclosed documentation
	The system can't be disposed together with the household waste. Disposal information can be found in the enclosed documentation.
	Do not dispose of the system together with the household waste but in accordance with the disposal regulations for electronic waste applicable at the installation site
	Warning: Explosives!
	Keep the battery modules away from open flame or ignition sources.

Warning signs

The warning signs contain important information for safe operation and shall not be torn or broken. Make sure that the warning signs are always placed properly. The broken sign must be replaced immediately

Parallel cables shall be installed in troughs or protected by metal pipes.



Danger!

Extremely dangerous situation leading to certain death or serious injury if the safety information is not observed.



Warning!

Dangerous situation leading to potential death or serious injury if the safety information is not observed.



Caution

Dangerous situation leading to potential injury if the safety information is not observed.



Notice

Indicates actions that may cause material damage.

Important Safety Instructions

Danger!

Danger to life due to high voltages in the inverter! All work must be carried out by qualified electrician



Danger!

The appliance is not to be used by children or persons with reduced physical sensory or mental capabilities, or lack of experience and knowledge, unless they have been given supervision or instruction.



Caution

Caution!

Danger of burn injuries due to hot enclosure parts!
During operation, the upper of the enclosure and the enclosure body may become hot.
Only touch the lower enclosure lid during operation.



Caution

Caution!

Possible damage to health as result of the radiation!
Do not stay closer than 20cm to inverter for any length of time.



Notice

Notice!

Grounding the PV generator.
Comply with the local requirements for grounding the PV modules and the PV generator. It is recommends connecting the generator frame and other electrically conductive surfaces in a manner which ensures continuous conduction and ground these in order to have optimal protection of system and persons.



Warning!

Warning!

Risk of electric shock!



Warning!

Warning!

Ensure input DC voltage \leq Max. DC voltage. Over voltage may cause permanent damage to system or other losses, which will not be included in warranty!



Warning!

Warning!

Authorized service personnel must disconnect both AC and DC power from system before attempting any maintenance or cleaning or working on any circuits connected to system



Warning!

Warning!

Do not operate the system when the device is running.

Setting of safety warning signs

- During guidance, maintenance and repair, please follow the instructions below to avoid non-professionals' misuse or accidents caused by non-professionals:
- Conspicuous signs should be placed at the front and rear switches to avoid accidents caused by mistake operation.
- A warning sign or cordon should be set near the operating area.
- The system must be reinstalled after maintenance or operation.

Measuring equipment

In order to ensure that the electrical parameters meet the requirements, relevant measuring equipment is required when the system is connected or tested. Make sure that equipment of matching specifications is connected and used in case arcs or shocks occur.

Moisture protection

Moisture is likely to damage the battery. For repair or maintenance, avoid or prevent operations in humid weather.

Operations after power-down

The battery system is part of the energy storage system, which can store life-threatening high voltages even when the direct current is turned off. Do not touch the battery socket. Even after the direct current or alternating current is cut off, the battery PACK can still maintain a life-threatening voltage. Therefore, for safety's sake, be sure to test the voltage with a calibrated voltage meter before the installation personnel operates the equipment.

Dispose and recycle

Dispose and recycle batteries properly according to the management rules of waste batteries in different countries. The recycling company is Smart Lifestyle Australia Pty Ltd.

1.4 Battery safety specification

Information about dangers

This product is a lithium iron phosphate battery, which meets the requirements of the UN's recommendations for the transportation of dangerous goods, tests and the UN38.3 certification. For batteries, chemical substances are stored in a sealed metal box designed to withstand the temperature and pressure encountered during normal use. Therefore, there is no physical danger of fire and explosion and chemical danger of hazardous goods leakage during normal use. However, if the product is exposed to any fire, mechanical shock, or electrical stress arising from misuse or is decomposed, the gas release port will be activated. The casing of the battery box will be broken to the limit, and harmful substances may be released.

Safety data table

For more information, please refer to the battery safety data table

1.5 General precautions



Warning!

There is a danger of chemical burns from the electrolyte or toxic gases. During normal operations, there will be no electrolyte leakage in the battery PACK and no toxic gases. If the battery PACK is damaged or malfunctions, there may be electrolyte leakage or toxic gases.

- Do not touch the battery with wet hands.
- Do not install or operate the battery in a potentially explosive environment or highly humid area.
- If moisture permeates the battery (e.g., due to the broken casing), do not install or operate the battery.
- Do not move the equipment that has been connected to a battery module. Fix the equipment in case it will tilt.
- The battery PACK must be transported by the manufacturer or designated personnel. The notes should be recorded and filed.

- A certified ABC fire extinguisher with a minimum capacity of 2 kg must be carried during transportation.
- During loading and unloading, do not smoke in and near the vehicle.
- If necessary, when replacing a battery module, please request new dangerous goods PACKaging and then PACKage it before handing it over to the supplier for collection.
- In the event of contact with the electrolyte, please carry out a rinse with clean water and then seek medical attention immediately.
- There is a risk of injury when lifting or dropping the equipment. The battery PACK is heavy. There is a risk of injury if the inverter or battery is improperly lifted or dropped when transported or attached to or removed from the wall.



Notice

Notice!

The battery system has a thermal runaway detection function: the system detects a thermal runaway (Venting of gaseous electrolyte; Burning of the cell, spark formation and ignition of vented gas mixtures; Explosion of the cell), it wirelessly sends a thermal runaway signal to the user's fire alarm system to inform the user that a thermal runaway has occurred. Users need to configure buzzer alarm products at home. (The alarm light is red, and the alarm buzzer has a sound level greater than 85dB but less than 110dB, with a frequency below 3.5kHz.)

1.6 Handle heavy loads safely

- When carrying heavy objects, you should be prepared to bear the weight to avoid being crushed or sprained by heavy objects.

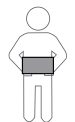

< 18 kg
(< 40 lbs)



18-32 kg
(40-70 lbs)



32-55 kg
(70-121 lbs)

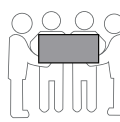

55-68 kg
(121-150 lbs)

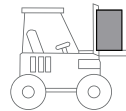



> 68 kg
(> 150 lbs)

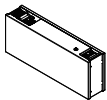
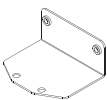

- When multiple people carry heavy objects at the same time, it is necessary to consider the height and other conditions, and do a reasonable job of personnel matching and division of labor to ensure a balanced weight distribution.
- When two or more people are carrying heavy loads together, one person should direct the equipment and lift or lower the equipment at the same time to ensure a uniform pace.
- When handling equipment by hand, you should wear protective gloves, labor protection shoes and other safety protective equipment to avoid injury.
- When carrying the equipment by hand, first approach the object, squat down, use the force of straightening your legs, do not use the strength of your back, slowly and steadily lift the object, and it is strictly forbidden to suddenly jerk or twist the torso.
- Do not quickly lift heavy objects to waist height, but place them on a half-waist high workbench or an appropriate place, adjust the position of your palms, and then lift them.
- Carrying heavy objects must be balanced and stable; The speed of movement should be uniform and low; Positioning is required to be smooth and slow, so as to avoid any impact or drop that scratches the surface of the equipment or damages the components and cables of the equipment.

1.7 List of installation accessories

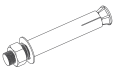
Check the parts list below to ensure that the accessories are complete.(Taking the installation of two battery packs as an example)

2x(Battery packing list)				
				
Battery pack	2x Mounting bracket	2x Battery bracket	M 5 *14 (8 PCS)	M 8 *60(4 PCS)

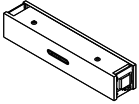
BMS Control box & base

				
1xBMS control box	1x base			

1.8 Limitation of liabilities

No direct or indirect responsibility will be assumed for product damage or property loss caused by the following situations:

- product modification, design alteration or parts replacement unauthorized by Smart Lifestyle;
- the serial number or seal is changed, modified or erased by non-technical personnel;
- failure to comply with local safety regulations (DE: VDE; AU: SAA);
- there is damage during transportation (including paint scratches caused by friction inside the PACKaging during transportation), where after the container/PACKage is unloaded and the damage is confirmed, a claim should be lodged immediately with the shipping or insurance company;
- failure to comply with any/all user manuals, installation guides and maintenance rules;
- improper or misuse of equipment;
- inadequate ventilation of equipment;
- failure to carry out maintenance in accordance with the standard maintenance procedure;
- force majeure (storms, lightning, fire, etc.);
- any damage caused by external factors.

2 Installation

2.1 Equipment Installation

Installation Precaution

Smart Lifestyle Australia battery product series is designed for outdoor installation (IP65). Make sure the installation site meets the following conditions:

- Not in direct sunlight.
- Not in areas where highly flammable materials are stored.
- Not in potential explosive areas.
- Not in the cool air directly.
- Not near the television antenna or antenna cable.
- Not higher than altitude of about 2000m above sea level.
- Not in environment of precipitation or humidity (>95%).
- Under good ventilation condition.
- The ambient temperature in the range of -20 C to +55 C .
- The slope of the wall should be within $\pm 5^\circ$.
- The wall hanging the inverter should meet conditions below
- The surface should be strong and flat.

Please note,

- Solid brick/concrete, or strength equivalent mounting surface
- The unit must be supported or strengthened if the wall's strength isn't enough (Such as wooden wall, the wall covered by thick layer of decoration)

Please **AVOID** direct sunlight, rain exposure, snow laying up during installation and operation.

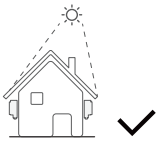

No direct sunlight

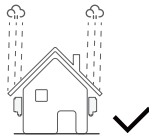

No rain exposure



No snow accumulation

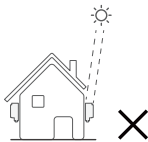

Direct sunlight



Rain exposure



Snow accumulation

2.2 Installation site and environment

General rules

Installation is not allowed in the following locations:

1. holes in ceilings or walls;
2. the roof that is not particularly suitable;
3. an entrance/exit area or below a staircase/passageway;
4. locations where humidity and condensed water exceed 90%;
5. places that salty and humid air can permeate;
6. earthquake zones where additional safety measures are required;
7. a site at an altitude of more than 2000 meters;
8. places with explosive environments;
9. a place exposed to direct Sunlight/rain or a place where the ambient
10. places with flammable materials or gases or explosive environments.

Restricted locations

Do not install the battery PACK series battery PACK in the following locations:

- (a) the restricted position determined for the panel in the as/NZS 3000;
- (b) no more than 600mm from any heat source (such as hot water heater unit, gas-fueled heater, air conditioning unit or any other equipment);
- (c) no more than 600mm from any exit;
- (d) no more than 600mm from any window or air vent;
- (e) no more than 900mm from the point connected to the 240V AC voltage;
- (f) no more than 600mm from the sides of other devices.

Make sure that when the battery is installed in any corridor, lobby or any similar place leading to an emergency exit, there is an adequate distance of at least 1 meter from the safety exit.

Residential barrier

In order to prevent a fire from spreading in the space where the energy storage system is installed, install a non-combustible barrier on the side of the wall or structural surface with its other side installed with the energy storage system. If the installation surface is not made of a non-combustible material, a non-combustible barrier can be installed between the energy storage system and the wall or structural surface.

If the energy storage system is installed on a wall or at a distance of 300mm from the wall that isolates the energy storage system from a residential space, the distance from other structures or objects must be increased. Be sure to keep the following distances:

- (i) at least 600mm between both sides of the battery;
- (ii) at least 600mm above the battery;
- (iii) the interval between multiple units installed should be at least 600mm.

If the distance between the energy storage system and the ceiling or any object above it is less than 50mm, the ceiling or structural surface above must be made of non-combustible materials and its radius should be within 600mm.

The distance between the highest point of the installed energy storage system and the ground or platform should not exceed 2.2 meters.

Unit:mm

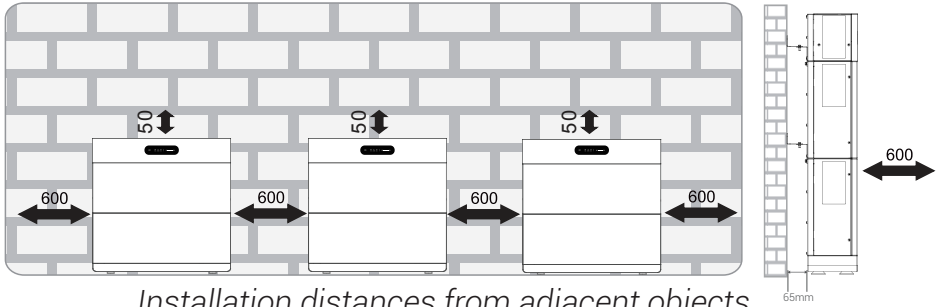

Installation distances from adjacent objects

Position	Min size
Left	600mm
Right	600mm
Top	50mm
Front	600mm
Back	65mm

2.2 Installation

System Appearance

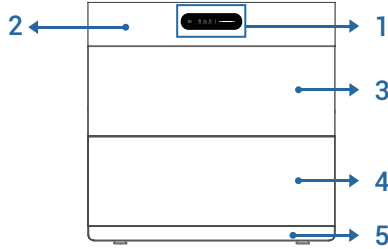

SLA-ESS-S1 Series	
1	LED Display Screen
2	BMS main box
3	Battery pack
4	Battery pack
5	Base

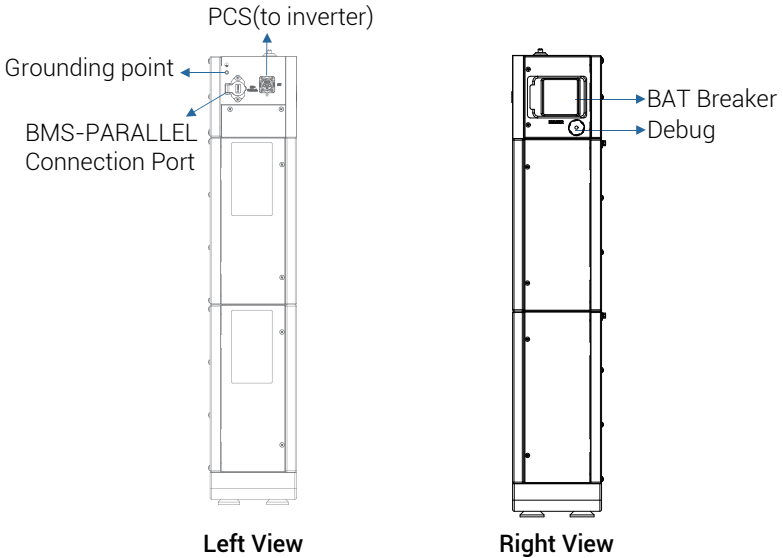



SLA-ESS-S1 Series user interface

Required for installation

Installation tools

			
Impact Drill (Φ10mm drill)	Torque Socket Wrench	Marker Pen	Vacuum Cleaner
			
Torque Wrench	Torque Screwdriver	Steel Tape	Level Ruler
			
Electric Batch (with M6 socket)	Multimeter	Rubber Mallet	Wire Stripper
			
Wire Cutting Pliers	Crimping Pliers (for PV terminals)	Art Knife	RJ45 Crimping Pliers
			
Crimping Pliers (for AC terminals)	Cable Ties	Hot Air Gun	Heat Shrink Tube
			
Anti-dirt Blanket	PV Plug Unlocking Tool		

Personal Protective Equipment

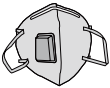
			
Safety Gloves	Safety Goggles	Dust Mask	Safety Shoes

Required for installation

The battery pack height must comply with local regulations. If the positioning plate conflicts with the regulations, the regulations must be met first.

Step 1: Determine the position of the base: mainly determine the height from the ground and the distance from the wall; The distance from the wall is 65mm, and keep horizontal;

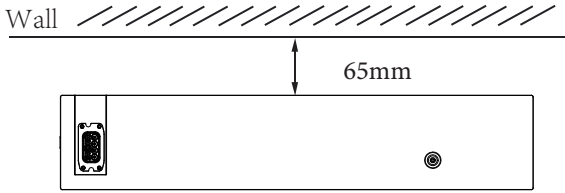

Step 2: Use four cross recessed pan head screws and a three component M5x14 unit to install the battery pack, and wall battery mounts. As shown in the following figure.

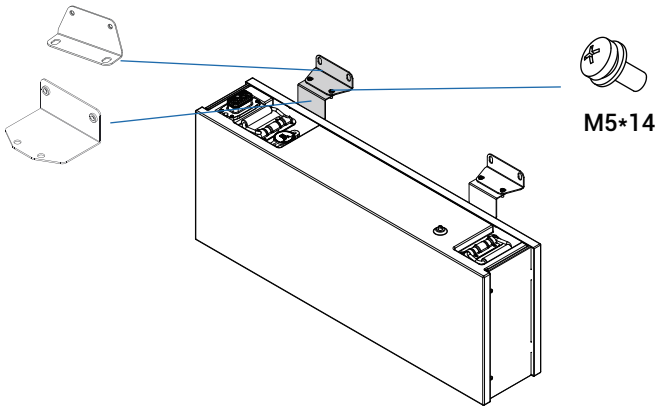

Step 3: Stack the installed batteries on top of the already placed base.

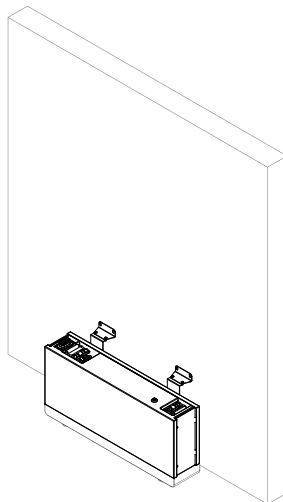

Step 4: Use a marker to draw dots at the red intersection in the following image. After drawing the dots, remove the wall battery pendant and use a drill bit to drill holes.

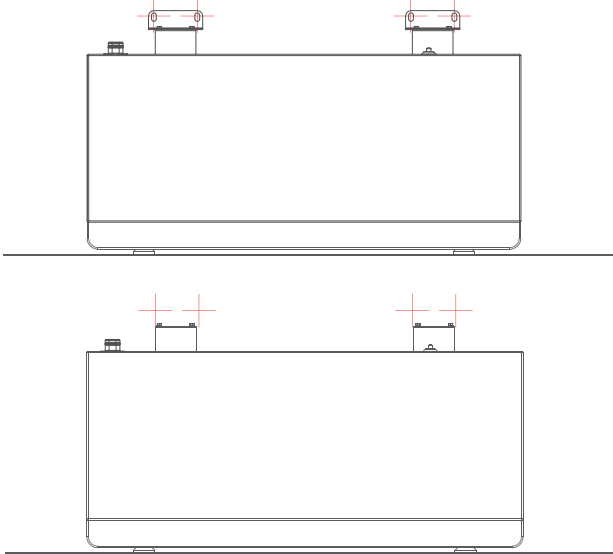

Step 5: Install expansion bolts in the drilled holes. Use the expansion bolt with its own M8 nut to fix the wall battery pendant with the expansion bolt. Afterwards, use four cross recessed pan head screws with M5x14 to fix the wall battery mount and pack mount.

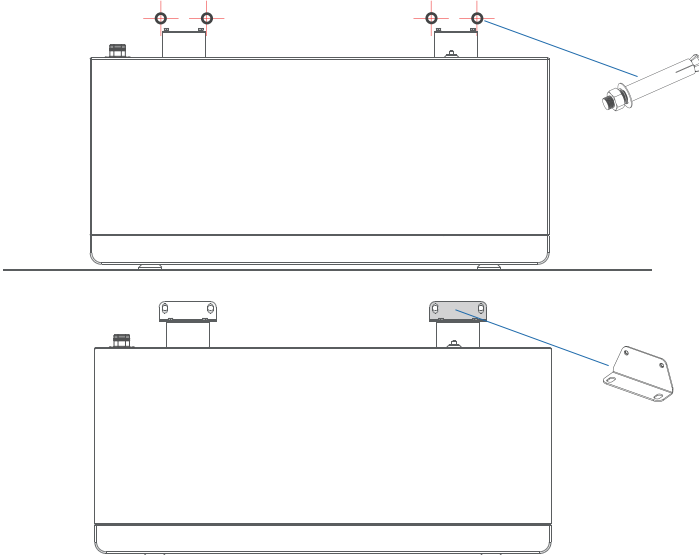

Step 6: Repeat steps 2 to 5 to install the other battery modules required. Please align the lower battery with the front of the upper battery during installation.

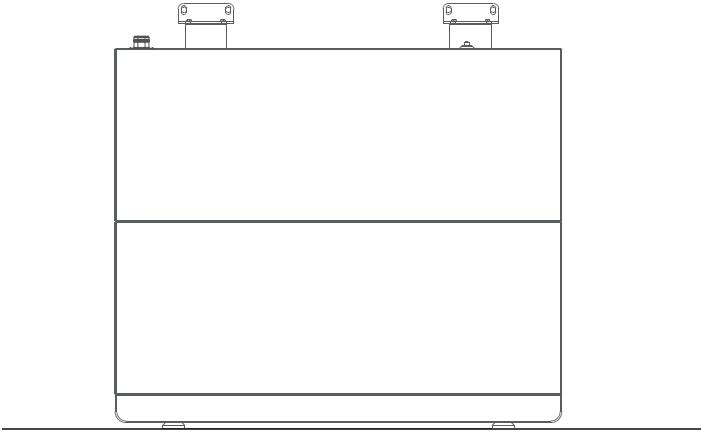

Step 7: After installing the battery module, place the high-voltage box on top of the battery box. Please align the high-voltage box with the front of the lower battery during installation.

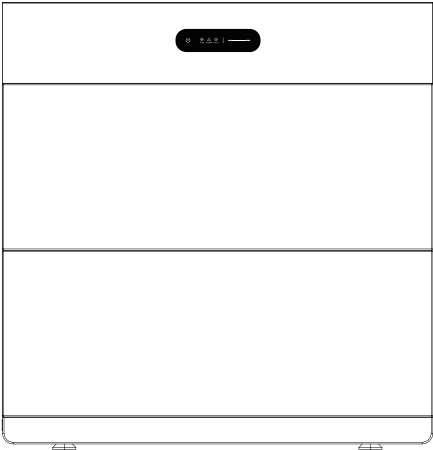

2.3 Communication connection

The communication between the BMS and the inverter is RS485 and CAN. The communication between pack and pack is Daisy chain. The communication between the BMS main box and the parallel BMS main box is CAN.

BMS communication can use the Pack-Inverter connection cable to communicate with the Inverter.

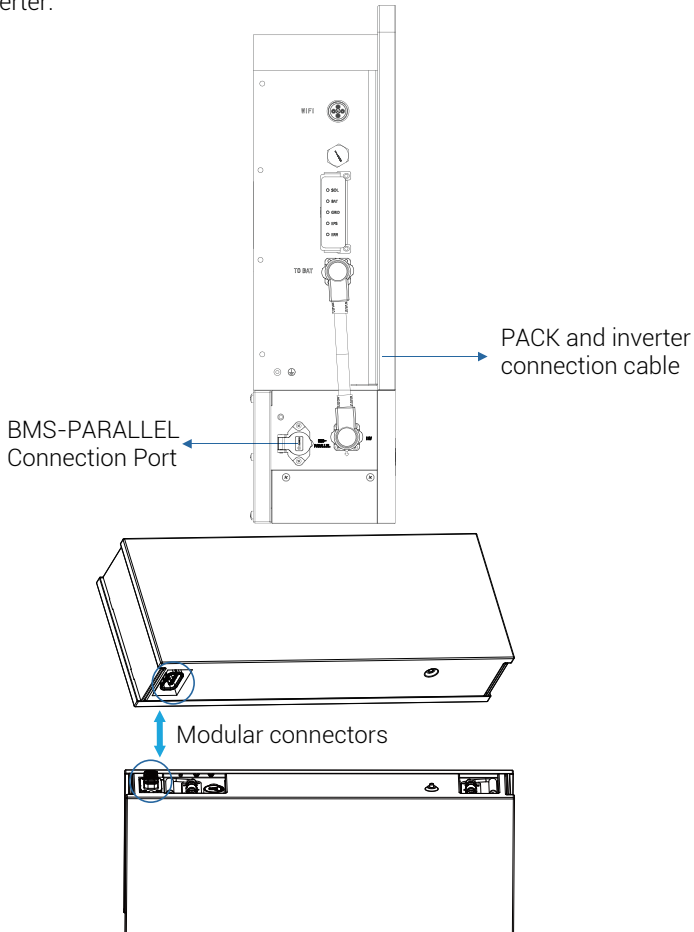

Precaution:

Remote monitoring of battery system is available as part of inverter energy system monitoring app. The monitoring data of the battery is communicated by using PCS port (using PCS-BAT cable) to the inverter.

2.4 Cable connection

The SLA-ESS-S1 system (without inverter) is cableless installation design which includes pre-installed internal connections. The modular stack installation directly plug-in and completes the series connection between battery modules. The connection between The SLA-ESS-S1 system (from BMS main box) and the inverter requires a cable connection using PCS-BAT connector which includes power connection, communication and grounding. Also, there' s a separate grounding connection between BMS main box and inverter.

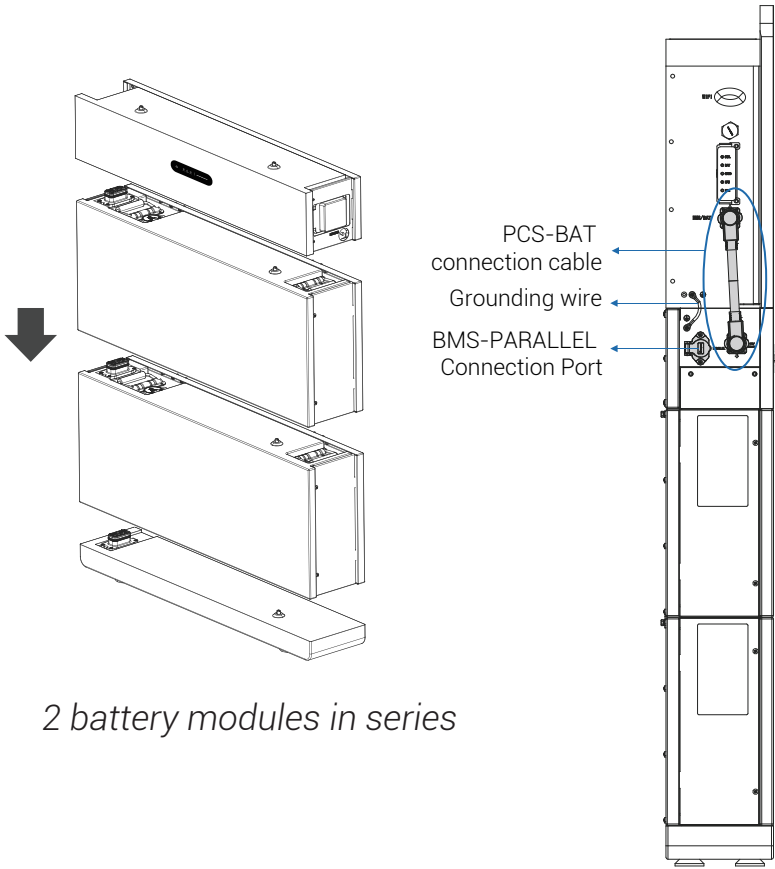

1.If you want to install the ,SLA-ESS-S1-30kWh series battery packs, you need to connect cables to the parallel ports of the two BMS main boxes. Parallel cables shall be installed in troughs or protected by a metallic cable duct or conduit. The metallic cable duct or conduit, provided that that metallic parts are connected with the equipotential bonding system and comply with IEC62477-2022 clause 4.4.4.2.2

WARNING:Parallel cables shall be installed in troughs or protected by metal pipes.

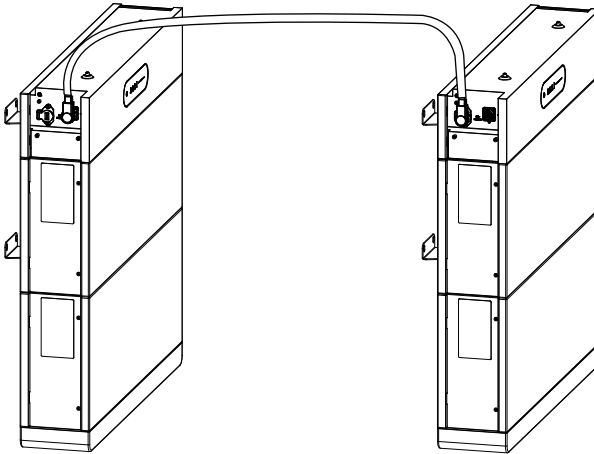

Two sets in paralleling

Precaution:

- 1 The product has a ground wire fixed at the grounding point of the BMS control box to connect to the inverter grounding point.
- 2 The PACK and PCS connection cable should not exceed three meters.
- 3 The grid port using the external wiring completes the grounding of the entire system
- 4 The battery shall used with hybrid inverter of SLA-ESS-S1 series.

2.5 Install grounding protection wire

Precautions



Danger!

Ensure that the protective ground wire is reliably connected. If it is not connected or becomes loose, it may pose an electrical shock hazard.



Notice

It is recommended to apply silicone or paint on the outside of the grounding terminal for protection after the grounding wire installation is completed.

Operation steps

Step 1: Crimp the OT terminal

Please note:

The installer will need to prepare the grounding wire. It is recommended to use a 10mm² yellow-green two-color single-core outdoor copper wire cable.

When stripping wires, please be careful not to scratch the wire core.

The cavity formed by the conductor crimping of the OT terminal should completely cover the wire core, and the wire core should be tightly and securely combined with the OT terminal without any looseness.

Heat shrink tubing or insulating tape should be used to cover the wire junction.

Please pay attention to protection when using a hot air gun to prevent the equipment from being burned.

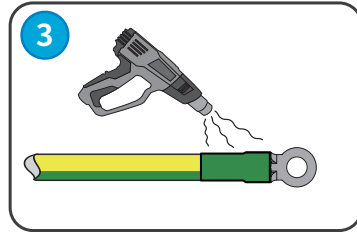
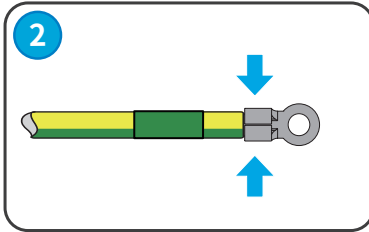
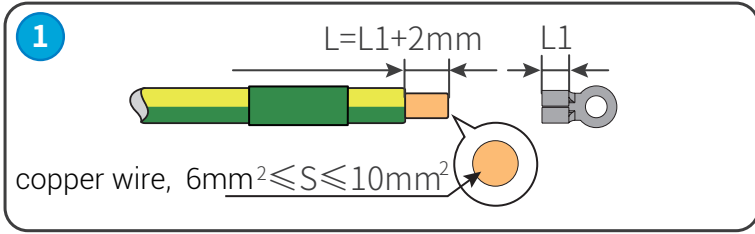

Step 2: Connect the grounding point of the inverter module to the external grounding ring network

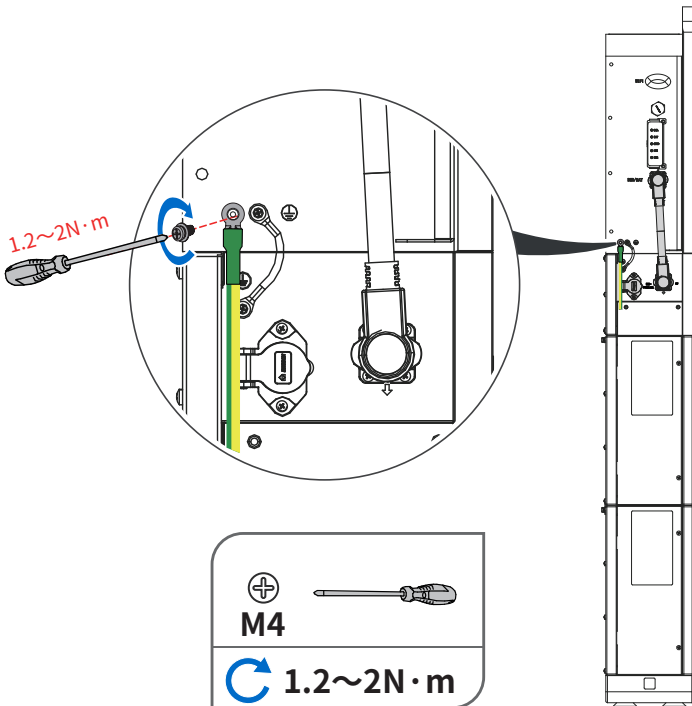

3. System operation

3.1 Start

Open the battery circuit breaker cover and switch on the BMS main box switch.

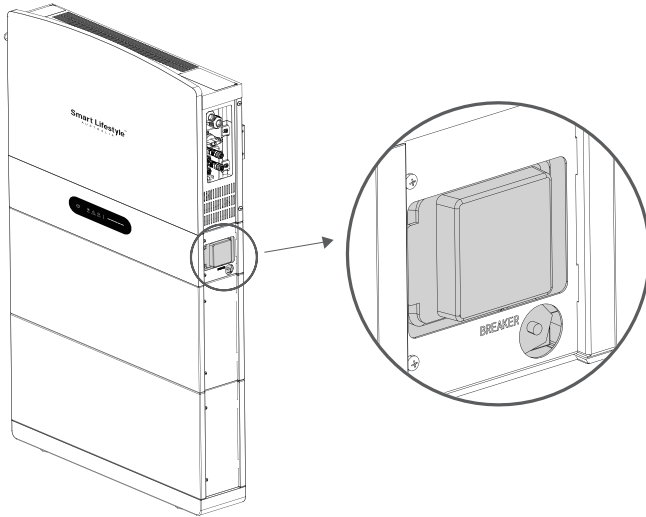

Precaution:

When using battery PACKs in parallel, if the indicator light of one of the BMS main box does not work, please check whether or not the cable of this battery is connected properly.

3.2 Turn off

1. Open the battery circuit breaker cover and switch off the BMS main box switch.

Precaution:

Please make sure that the battery is not being charged or discharged before performing a shutdown.

3.3 Emergency procedure

Emergency response plan

1. Check the control power supply, if it is normal, check the power supply again to find out the cause.

2. Please record every detail related to the fault for analysis and troubleshooting. Do not perform any operation on the equipment while it is malfunctioning. Please contact Smart Lifestyle service support as soon as possible.
3. Since the battery contains a small amount of oxygen, and all batteries have explosion-proof valves, there is almost no chance of explosion.
4. When the battery indicator is lit red to indicate a fault, check the fault type through the communication protocol and contact our aftersales personnel for consultation.

Hazards

If the battery PACK leaks the electrolyte, avoid contact with the leaking liquid or gas. If you come into contact with the leaking matter, take the following measures immediately:

Inhalation: Leave the contaminated area and seek medical attention.

Eye contact: Rinse eyes with tap water for 5 minutes and then seek medical attention.

Skin contact: Wash the affected area thoroughly with soap and water and seek medical attention.

Eating by mistake: Seek medical attention if vomiting occurs

Fire

If a fire occurs at the battery PACK installation location, please perform the following operations:

Fire extinguishing media

No respirator is required for normal operations. Burning batteries cannot be extinguished with ordinary fire extinguishers but special fire extinguishers, such as Novec1230, FM-200 or dioxin fire extinguishers. When not caused by a battery, a fire can be extinguished with ordinary ABC fire extinguishers.

Fire protection instructions

1. If a fire occurs while the battery is charged, disconnect the battery PACK and cut off the circuit breaker of the charging power supply under safe conditions.

2. If the battery PACK has not caught fire, please put out the fire before the battery PACK catches fire.
3. If the battery PACK catches fire, do not try to extinguish the fire but evacuate people immediately.

Precaution:



Warning!

When the temperature of the battery exceeds 150°C, it may explode. The burning battery PACK will leak toxic gases, do not approach it.

Effective ways to deal with accidents

Batteries in dry environments: Place the damaged battery in an isolated place and notify the local fire department or service engineer. Batteries in humid environments: If any part of the battery or inverter or any wiring part is submerged, do not touch any of them. Do not use again the damped or submerged battery, please contact the maintenance engineer in time.

3.4 Product protection

Radiation protection

This product uses electronic components and materials that comply with international safety standards and has undergone rigorous electromagnetic compatibility testing to ensure that it does not pose any harmful radiation to the human body during normal use.

Vibration protection

This product has considered the potential impact of vibration on users during design and has reduced vibration during product operation by optimizing the structure and selecting high-quality materials.

Do not use this product in poorly ventilated environments; do not expose this product to acidic, alkaline, or other corrosive gases; if you need to clean or maintain the product, please isolate it from corrosive gases and take corresponding protective measures.

Protection against corrosive liquids

Do not expose this product to acidic, alkaline, or other corrosive liquids; if you need to clean or maintain the product, please isolate it from corrosive liquids and take corresponding protective measures; if corrosion appears on the surface of the product, please stop using it immediately and contact the after-sales service center for inspection or replacement.

4. Battery status description

4.1 Battery System LED Display Description



Table1 LED display description

State	Description	RUN	ALARM	FAULT	Battery SOC indicator	Discription
Battery system power-up	Normal	on	off	off	Based on real SOC power indication	Standby mode
	Warning	on	Blinking ^{1[1]}	off		Equipment is operational but requires maintenance
	Fault	off	off	Blinking ^{2[1]}		Device not functioning

Table 2 Battery SOC LED Lights Description

State	Charge mode					Discharge mode					Standstill mode				
	L1	L2	L3	L4	L5	L1	L2	L3	L4	L5	L1	L2	L3	L4	L5
SOC LED lights	●	●	●	●	●	●	●	●	●	●	●	●	●	●	●
SOC	0~20%	One by one light up	Off	Off	Off	Off	Blinking ^{2[1]}	Off	Off	Off	Off	On	Off	Off	Off
	20%~40%	One by one light up	Off	Off	Off	On	Blinking ^{2[1]}	Off	Off	Off	On	On	Off	Off	Off
	40%~60%	One by one light up	Off	Off	Off	On	On	Blinking ^{2[1]}	Off	Off	On	On	On	Off	Off
	60%~80%	One by one light up	Off	Off	Off	On	On	On	Blinking ^{2[1]}	Off	On	On	On	On	Off
	80%~100%	One by one light up	Off	Off	Off	On	On	On	On	Blinking ^{2[1]}	On	On	On	On	On

[1] refer to explanation table 3

Table 3 Description of LED Blinking

Type	On	Off
Blinking1	0.5s	2s
Blinking2	0.75s	1s
One by one light up	0.5s Forward one frame	



Notice

The left status indicator and the right battery capacity indicator are judged independently of each other.

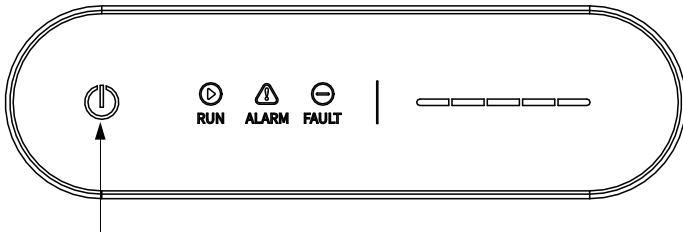

When the battery system is switched on, the power button indicator lights up.
 When the battery system is disconnected, the power button indicator turns off

Power light State:

When RESS is turned OFF, the power light status will be "OFF". When RESS is turned ON, the power light status will be "ON". In order to switch "ON" or "OFF" the RESS, we can use the following steps as given below:

Operation steps:

- 1, Short press the power button less than 1s, vertical light will flash within 5s;
- 2, Then long press the power button for 5s to 15s, the vertical light will be on for few seconds and turn off and then the power light will turn "ON".

To make sure the steps are correct, power light should be "ON" and vertical light should be "OFF".

**Notice**

If in step2, long press is not within the range of 5s to 15s, the vertical light will flash and power light will remain "OFF";

If no effective press again within 5s (While the Vertical light is flashing, and power light is off,), it will be back to the initial state (vertical light will turn "OFF", and power light is "OFF").

If press effectively again (long press 5s to 15s) , the power light will turn "ON" and vertical light will turn "OFF".

5. Battery storage and recharging

5.1 Battery storage requirements

Storage environment requirements:

–Store batteries in a dry and well-ventilated place at room temperature or lower.

While batteries can be used safely between -20 and 55 °C (-4 to 131 °F), it is strongly suggested to avoid storing them at a temperature that is close to the upper or lower range.

- Storing batteries in a refrigerator may create internal condensation when the battery is brought to room temperature, and they may become dangerous when operated.
- It is best to have a reserved area ONLY for lithium-ion battery storage. It has to be a cool and dry place, away from heat sources.
- The area should be maintained free from any materials which can catch fire such as wood tables, carpet, or gasoline containers. The ideal surface for storing lithium-ion batteries is concrete, metal, or ceramic or any non-flammable material.

- Batteries can be stored in a metal cabinet such as a chemical-storage cabinet, make sure that batteries are not touching each other.
- It is recommended to have in place a fire detector in the storage area.
- Never leave batteries unattended where they can be damaged by someone.
- Have a class ABC or CO2 fire extinguisher nearby the storage area.
- Make sure the working surface is made of a material that is not conductive and non-combustible. If you are working on a conductive material cover the surface with an insulating material.
- The area should be clear of any flammable or combustible materials such as wood tables, carpet and gasoline or other solvent.
- Keep the area free from any sharp objects that may puncture the insulating
- Keep the area free from any sharp objects that may puncture the insulating

5.2 Storage expiration

In principle, it is not recommended to store the battery for a long time. Be sure to use it in time. The stored batteries should be disposed according to the following requirements.

Stored lithium battery recharging interval

Required Storage Temperature	Recharge Interval
0°C ~ +45°C	6 months

- 1 If a battery is deformed, broken or leaking, discard it immediately regardless of its storage time.
- 2 The allowable maximum stored battery recharging period is 3 years and the allowable maximum stored battery recharging times is 3. For example, if recharging is performed once every 6 months, the allowable maximum recharging times is 3 times; if the allowable maximum stored battery recharging period or times is exceeded, it is recommended to discard the battery.

- 3 A lithium battery will have its capacity decreasing after being stored for a long time, and typically will have its capacity irreversibly decreasing by 3%–10% after being stored at the recommended storage temperature for 12 months. If the customer conducts the discharge test and acceptance according to the specification, there is a risk that the battery with a capacity less than 100% after being stored will fail the test.

5.3 Inspection before battery recharging

Before recharging a battery, check its appearance: Deformation/Shell. damage/Leakage

5.4 Recharge Operation Steps

NOTICE: It is not recommended for users to charge the battery packs by themselves. It is recommended to contact professional after-sales staff for operation.

- Step 1:** Connect power cables to the battery charger correctly. The power cables must be compatible with the product interface, which should include Battery positive and negative power wires and RS485 communication wires. Users can use host software by RS485 communication to monitor the status of battery packs in real-time.
- Step 2:** Turn on the BMS main box DC breaker to ON. Check the LED on the BMS main box is on.
- Step 3:** Turn on the battery charger.
- Step 4:** Set charging parameter on the battery charger.
Case #1, Two battery PACKs are charged. Set the charge limited voltage 205 V;
Set the charge limited current 25A;
Case #2, Six battery PACKs are charged. Set the charge limited voltage 307.2V;
Set the charge limited current 50A;
- Step 5:** After the battery is charged, switch off the battery charger and the battery DC breaker. Disconnect the power cables.

6. Battery port definition and parameters

6.1 Port definition

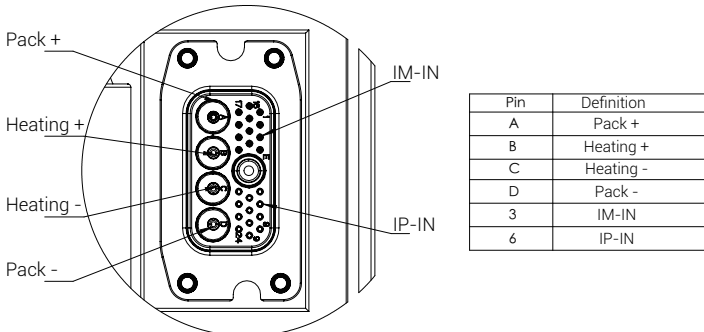
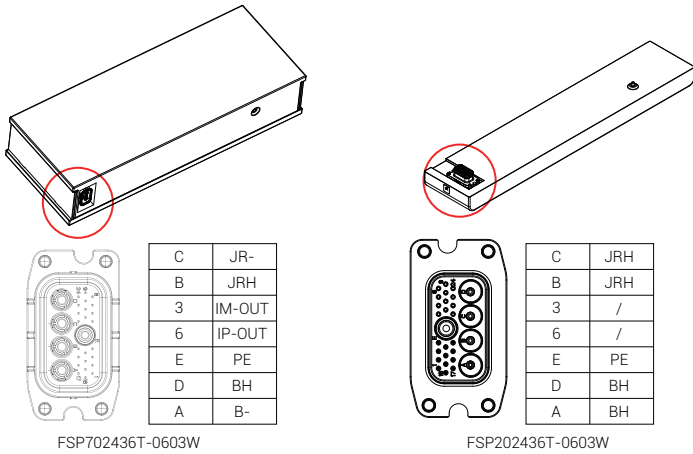
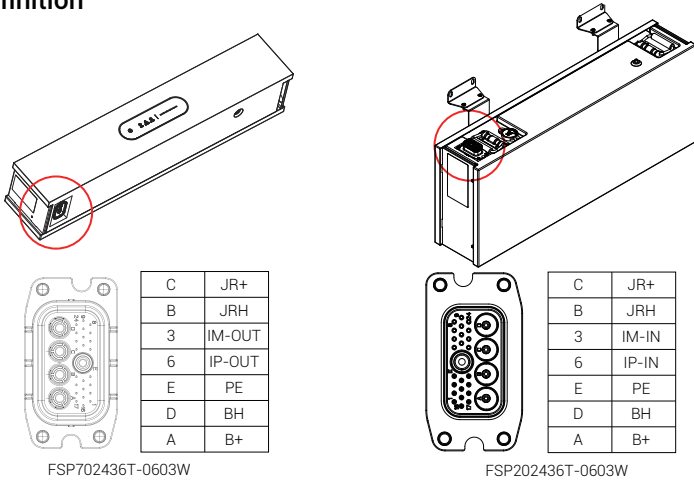

6.2 Internal wiring of the system

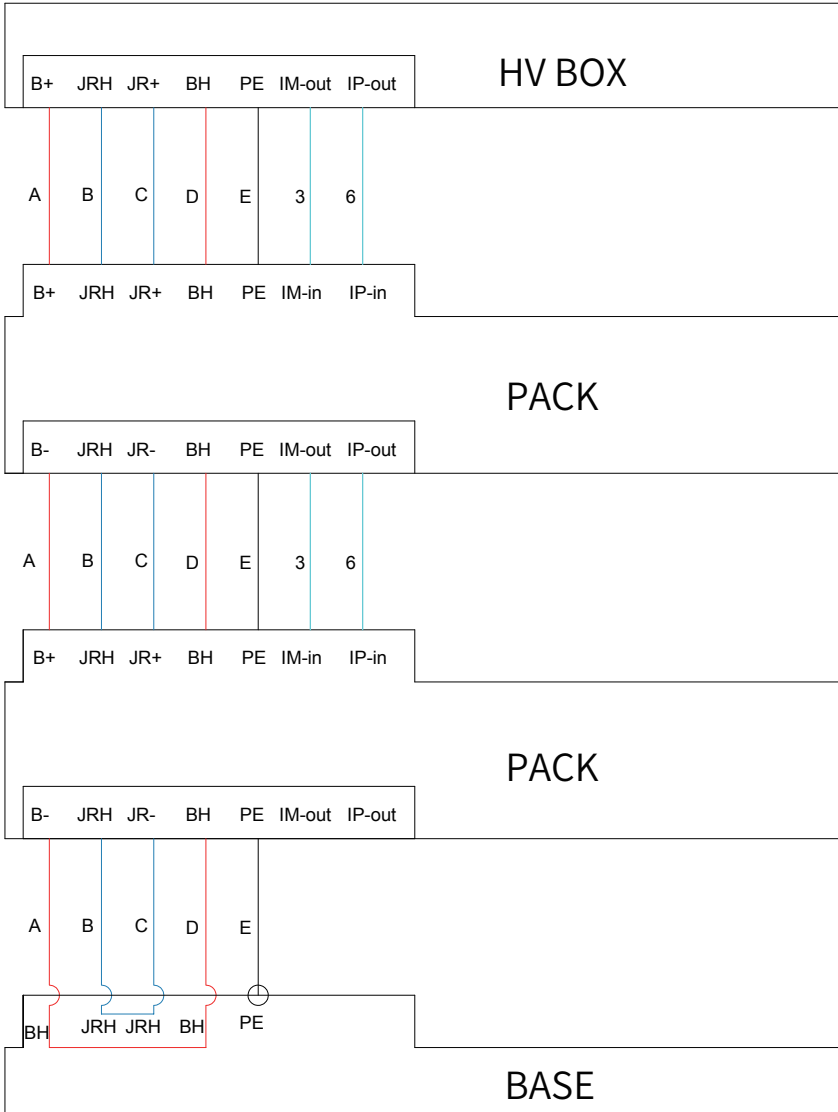

Description :

'B+' and 'B-' are positive and negative pole output lines of the battery pack.

'BH' is Negative electrode input line of BMS main box.

'PE' is ground line.

'IM-OUT' and 'IP-OUT' is daisy chain output connection interface

'IM-IN' and 'IP-IN' is daisy chain input connection interface

'JR+', 'JR-' are heating film input and output line of battery pack.

'JRH' is negative electrode output of BMS main box heating film.

'NA' indicates that this interface is undefined.

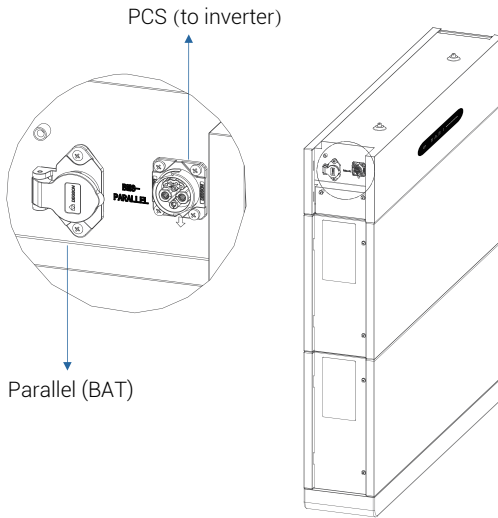

PARALLEL(BAT) interface

The communication between parallel battery packs is RS485 and CAN.

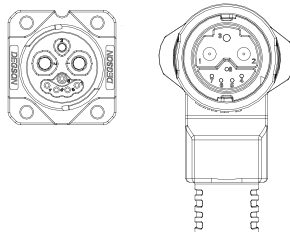

PARALLEL(BAT) interface pin definition

1	2	3	4	5	6	7	8
P'+	P'-	GND	485A	485B	CAN2H	CAN2L	GND

PCS-BAT Interface

The communication between PCS and BAT is RS485 and CAN.

PCS-BAT interface pin definition

1	2	3	4	5	6	7	8
P+	P-	GND	485A	485B	CANH	CANL	GND

6.3 Battery parameters

Mode	SLA-ESS-S1-5kWh	SLA-ESS-S1-10kWh	SLA-ESS-S1-15kWh	SLA-ESS-S1-20kWh	SLA-ESS-S1-30kWh
Component	Base+BMS + 1*Module	Base+BMS + 2*Module	Base+BMS +3*Module	2*(Base+BMS +2*Module)	2*(Base+BMS +3*Module)
Nominal Voltage	102.4 V	204.8 V	307.2 V	204.8 V	307.2 V
Maximum protection voltage	116.8 V	233.6 V	350.4 V	233.6 V	350.4 V
Maximum protection voltage	89.6 V	179.2 V	268.8 V	179.2 V	268.8 V
Number of Battery Modules	1	2	3	4	6
Rated Capacity	50 Ah	50 Ah	50 Ah	100 Ah	100 Ah
Total Energy	5.1 kWh	10.2 kWh	15.3 kWh	20.4 kWh	30.6 kWh
Nominal Power	2.56 kW	5.12 kW	7.68 kW	10.24 kW	15.36 kW
Maximum Charge/Discharge Current	30 A	30 A	30 A	50 A	50 A
Cycle life	6000 Cycles (at 25°C, 0.5C, 90% DoD, 70% SoH)				
Expected life time	10 Years (70% SoH)				
Operating Ambient Temperature	-20°C to 55°C				
Storage Temperature	-20°C to 45°C (3 months)				
	-20°C to 35°C (1 year)				
Humidity	0% - 95%				
Altitude	Below 2000 m				
Ingress Protection	IP65				
Switch on/off	Button*1 +Breaker*1	Button*1 +Breaker*1	Button*1 +Breaker*1	2* (Button*1 +Breaker*1)	2* (Button*1 +Breaker*1)
Certificate	CE, IEC 62619, IEC 62040, IEC 60529, IEC 61000, UN 38.3				
Weight	69±4 kg	124±6 kg	179±8 kg	248±12 kg	358±16 kg
Dimension(W*H*D)	800±20*840 ±30*160±20 mm	800±20*840 ±30*160±20 mm	800±20*1150 ±30*160±20 mm	1600±20*840 ±30*160±20 mm	1600±20*1150 ±30*160±20 mm
Remark	1 Series			2 Series Parallel	

7. Routine maintenance

Note that the maintenance should be conducted by certified electricians.

7.1 Maintenance plan

1. Check whether or not any wire connection is loose.
2. Check whether or not any cable is aging/broken.
3. Check whether or not any cable insulation peels off.
4. Check whether or not any cable terminal screw is loose and whether or not there is any sign of overheating.
5. Check whether or not the grounding connection is proper.

Operating environment

(Every six months) carefully observe whether or not the battery system equipment malfunctions or is broken; listen for abnormal noises in various parts of the inverter when the inverter is running.

While the inverter is running, check whether or not the parameters such as the voltage, temperature, etc. of the battery and other equipment parameters are normal.

Equipment cleaning

(Once every six months to a year, depending on the site environment and dust content, etc.) make sure that the ground is clean, the maintenance channel is unobstructed and that the warning and guidance signs are clear and intact. Monitor the temperature of the battery module and clean the battery module if necessary.

Equipment inspection

Once every six months to one year

1. Check whether or not any cable connection is loose.
2. Check whether or not any cable is aging/broken.
3. Check whether or not any cable tie falls off.
4. Check whether or not any cable terminal screw is loose and whether or not there is any sign of overheating in the terminal position.
5. Check whether or not any management system of the inverter and battery equipment, monitoring system or other related equipment malfunctions or is broken.

6. Check whether or not the equipment is well grounded and the grounding resistance is less than 10 ohms.

7.2 Cautions

After the equipment stops running, please pay attention to the following matters during maintenance:

1. Operations and maintenance shall comply with the relevant safety standards and regulations.
2. Disconnect all electrical connections to prevent the equipment from being energized.
3. Appropriate protective measures should be taken during maintenance, such as insulating gloves, shoes, noise-proof earplugs, etc.
4. Life is priceless. Make sure that no one will get hurt first.
5. In the case of deep discharge, if the whole inverter is in a static state (i.e., the battery has not been charged for two weeks or more), the battery must be charged to an SOC of 30% to 50%.
6. Equipment maintenance can only be carried out by professionals. Maintenance personnel are forbidden from opening any equipment module by themselves.

This manual is only used as a guide and reference for installation and operations. If there is any matter not specified in this manual, please contact us in time.

8. Fault codes and solutions

When you encounter any of the following problems, please refer to the following solutions. If the problem is still not resolved, please contact your local distributor. The following table lists some basic problems that may occur during actual operations and corresponding basic solutions to the problems.

Error codes and troubleshooting

Fault code	Fault name	Solution
1	BMS communication failure	Switch off the grid side AC circuit breaker, PV DC switch and battery circuit breaker, then switch them on 5 minutes later. Contact SLA service if the problem persists.
2	Battery overvoltage alarm	Switch off the grid side AC circuit breaker, PV DC switch and battery circuit breaker, then switch them on 5 minutes later. Contact SLA service if the problem persists.
3	Battery undervoltage alarm	Switch off the grid side AC circuit breaker, PV DC switch and battery circuit breaker, then switch them on 5 minutes later. Contact SLA service if the problem persists.
4	Battery over temperature alarm	Switch off the grid side AC circuit breaker, PV DC switch and battery circuit breaker, then switch them on 5 minutes later. Contact SLA service if the problem persists.
5	Battery under temperature alarm	Switch off the grid side AC circuit breaker, PV DC switch and battery circuit breaker, then switch them on 5 minutes later. Contact SLA service if the problem persists.
6	Battery overcurrent alarm	Switch off the grid side AC circuit breaker, PV DC switch and battery circuit breaker, then switch them on 5 minutes later. Contact SLA service if the problem persists.
7	Battery voltage difference too large	Switch off the grid side AC circuit breaker, PV DC switch and battery circuit breaker, then switch them on 5 minutes later. Contact SLA service if the problem persists.
8	Temperature difference too large	Switch off the grid side AC circuit breaker, PV DC switch and battery circuit breaker, then switch them on 5 minutes later. Contact SLA service if the problem persists.
9	Battery SOC too high	Switch off the grid side AC circuit breaker, PV DC switch and battery circuit breaker, then switch them on 5 minutes later. Contact SLA service if the problem persists.
10	Battery SOC too low	Switch off the grid side AC circuit breaker, PV DC switch and battery circuit breaker, then switch them on 5 minutes later. Contact SLA service if the problem persists.
11	Other battery alarms	Switch off the grid side AC circuit breaker, PV DC switch and battery circuit breaker, then switch them on 5 minutes later. Contact SLA service if the problem persists.

12	DC bus over voltage	Switch off the grid side AC circuit breaker, PV DC switch and battery circuit breaker, then switch them on 5 minutes later. Contact SLA service if the problem persists.
13	DC bus under voltage	Switch off the grid side AC circuit breaker, PV DC switch and battery circuit breaker, then switch them on 5 minutes later. Contact SLA service if the problem persists.
14	PCS over temperature	<ol style="list-style-type: none"> 1. Check the ventilation and the ambient temperature at the installation location. 2. If the ventilation is poor or the ambient temperature is too high, improve the ventilation and heat dissipation. 3. Contact SLA service if both the ventilation and the ambient temperature are normal.
15	Battery side DC over voltage	<ol style="list-style-type: none"> 1. If the problem occurs occasionally, check battery input voltage, if it 's within normal range, the inverter will recover automatically. 2. Contact SLA service if the problem occurs frequently.
16	Battery side DC under voltage	<ol style="list-style-type: none"> 1. If the problem occurs occasionally, check battery input voltage, if it 's within normal range, the inverter will recover automatically. 2. Contact SLA service if the problem occurs frequently.
17	Recharge abnormal	Switch off the grid side AC circuit breaker, PV DC switch and battery circuit breaker, then switch them on 5 minutes later. Contact SLA service if the problem persists.
18	Hardware Battery Over Voltage	Switch off the grid side AC circuit breaker, PV DC switch and battery circuit breaker, then switch them on 5 minutes later. Contact SLA service if the problem persists.

Protection codes and description

0x340 DATE4,5	Protecting Flag	Troubleshooting
BIT2	BMS communication failure	Turn off the high-voltage box switch in the version and start it after 10 seconds. If there is still a problem, contact the maintenance personnel
BIT3	Battery overvoltage alarm	Please connect PCS discharge
BIT4	Battery undervoltage alarm	Please connect PCS for charging
BIT5	Battery overtemperature alarm	Please shut down the machine and wait for recovery. It cannot be restored within 2 hours. Contact the maintenance personnel
BIT6	Battery undertemperature alarm	Please connect the PCS, the system will automatically heat the battery, and it cannot be restored within 2 hours. Contact the maintenance personnel
BIT7	Battery overcurrent alarm	It will automatically recover. If it persists for a long time, please shut down the machine and contact the maintenance personnel
BIT8	Battery voltage difference too large	Unable to resume contact with maintenance personnel after 2 hours of shutdown
BIT9	Temperature difference too large	Unable to resume contact with maintenance personnel after 2 hours of shutdown
BIT10	Battery SOC too high	Please connect PCS discharge
BIT11	Battery SOC too low	Please connect PCS for charging
BIT12	Other battery alarms	Turn off the high-voltage box switch and start the machine 10 seconds later. If there is still a problem, contact the maintenance personnel

9. Quality commitments

If the product malfunctions during the warranty period, Smart Lifestyle or its distributors will provide free service or replace it with a new product.

Documents

During the warranty period, the customer shall provide the product purchase invoice and date. In addition, the trademark on the product shall be intact and clear. Otherwise Smart Lifestyle has the right to refuse to fulfil the warranty.

Criteria

- The unacceptable product replaced will be disposed by Smart Lifestyle.
- The customer should allow Smart Lifestyle or its distributors to take reasonable time to repair the malfunctioning equipment.

Exemption from liabilities

In any of the following cases, Smart Lifestyle has the right to refuse to fulfil the warranty:

- The warranty period of the whole device/parts has expired;
- The equipment is broken during transportation;
- The equipment is installed, reinstalled or used improperly;
- The equipment is used in any of the harsh environments described in this manual;
- The malfunction or breakage is caused by installation, repair, modification or disassembly performed by the service provider or the personnel other than Smart Lifestyle's or its authorized partners' personnel;
- The malfunction or damage is caused by abnormal use or use non-compliant with Smart Lifestyle's standards.

Components or software

- The scope of installation and use does not comply with relevant international standards.
- Any damage caused by accidental natural factors.

For the product that malfunctions in any of the above cases, if the customer requires maintenance, we can provide paid maintenance services based on Smart Lifestyle's judgment.

10. Remote access

10.1 Operation instructions

requires valid authentication information, such as a username and password.

Before remote access, ensure that the network connection is stable. Otherwise, operations may be affected. During remote access, you need to pay attention to the machine running status to avoid machine faults caused by misoperations.

10.2 Safety instructions

Remote access requires encrypted communication to ensure security during data transmission.

You need to record operation logs for remote access.

Permission management must be configured for remote access to ensure that only authorized personnel can perform operations.

Risk assessment must be performed for remote access and security specifications must be set for different maintenance tasks to ensure operation security.

Appendix A

PV Connection Steps

Step 1: Checking PV module.

- 1.1 Use the digital multimeter to measure the whole installed PV system voltage.
- 1.2 Check the PV+ and PV- from the PV string combiner box correctly.
- 1.3 Please make sure the impedance between the positive pole and negative pole of PV to earth should be open circuit (infinite).

Step 2: Separating the DC connector.

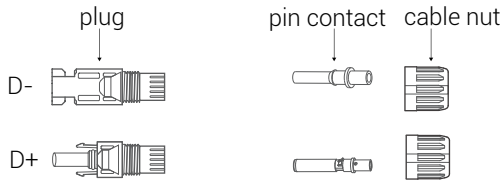

Step 3: Wiring

- 3.1 Choose the 4 mm² (12 AWG) wire to connect with the cold-pressed terminal.
- 3.2 Remove 10mm of insulation from the end of wire.
- 3.3 Insert the insulation into pin contact and use crimping plier to clamp it.

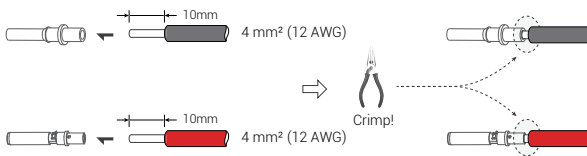

Step 4: Insert pin terminal through the cable nut to assemble into back of the male or female plug. When you feel or hear a "click" sound the pin terminal assembly is seated correctly.

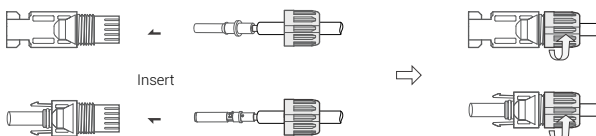

Step 5: Plug the PV connector into the corresponding PV terminals on inverter

Appendix B

Two Poles Isolation

The battery packs are connected to the “Base” at the bottom and to the HV box / battery management system (BMS) at the top. Since it is a modular stack installation, which directly plugs-in and completes series connection between battery modules, and base, BMS, it ensures that 2 pole isolation is maintained within.

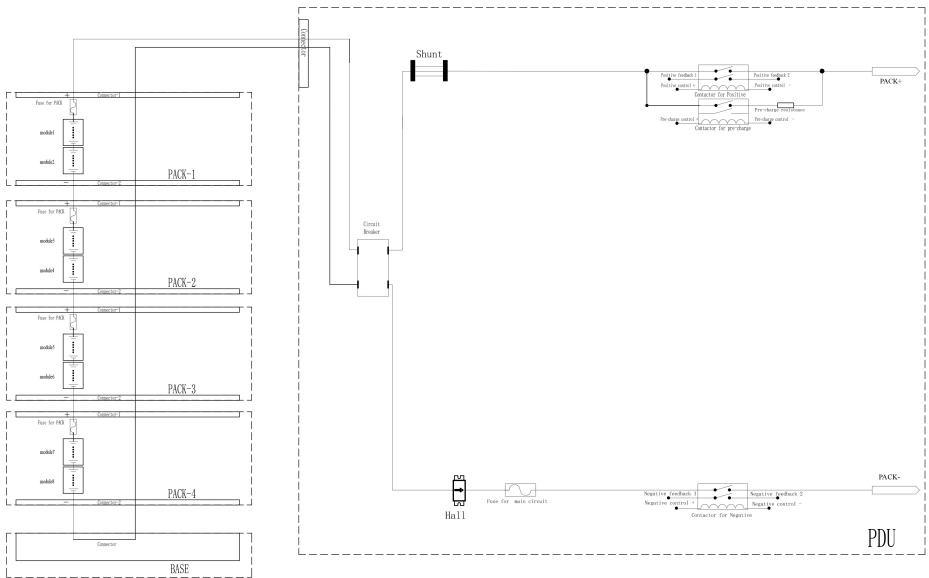

Smart LifestyleTM

A U S T R A L I A

■ Ph: 1300 198 955 ■ ABN 54 652 113 561

■ info@smartlifestyleaustralia.com.au

■ smartlifestyleaustralia.com.au

Office Address

■ Unit 1, 41 Anzac St, Greenacre, NSW 2190

■ 16 Fastline Road Truganina VIC 3029